

VEE RAY FILTAMAX

EF30, EF35, EF40

- Mobility and space saving features
- Powerful reversible 1/3 HP pump
- Full stainless steel construction
- Reusable filter bag
- Upgrade kit to carbon pad filtering
- Easy clean
- Easy service



EF35

Overall Construction

- Full stainless steel construction
- Mounted on two fixed and two swivel castors
- 1/3 HP motor, reversible, heavy duty pump
- Heavy duty motor switch
- Rigid return delivery tube for safe, efficient, return of oil and shortening to fryer tank
- Reusable 'easy clean' filter bags, with upgrade kit to carbon pad filtering available
- Heavy duty stainless steel handle
- Cord storage
- Heavy duty heat resistant handle fitted to oil delivery tube

Controls

- Off/Forward/Reverse pump control

Cleaning and Servicing

- Open stainless steel pan for easy clean
- Easy clean stainless steel exterior

VEE RAY FILTAMAX

EF30, EF35, EF40

Specifications

Pump

1/3 HP single phase reversible pump

Electrical requirements

220 - 240 V.a.c., 50/60 Hz, 1 P+N+E, 3.2A

110 - 120 V.a.c., 50/60 Hz, 1 P+N+E, 6.4A

Electrical connection

62mm from RH side, 365mm from rear, and 440mm from floor

3 pin 10A plug cordset fitted

Filtering capacity

EF30	20 litres
EF35	30 litres
EF40	32 litres

Fryer compatibility

EF30	GT45/E GT46/E
EF35	E43/E E44/E
EF40	GT60/E GT60-HPO/E

Under fryer storage

EF30	GT45/E GT46/E
EF35	N/A
EF40	GT60/E GT60-HPO/E

Dimensions

EF30

Width 324mm
Depth 683mm
Height 562mm

EF35

Width 324mm
Depth 735mm
Height 562mm

EF40

Width 474mm
Depth 683mm
Height 562mm

Nett weight

EF30

24kg

EF35

26kg

EF40

28kg

Packing data

EF30

0.28m³, 51kg

EF35

0.28m³, 53kg

EF40

0.28m³, 55kg

Options at extra cost

Additional filter bags

Carbon pad upgrade kit (Part No. 025669)

Flexible hose with stay cool handle (Part No. 020417)

Drain adaptor kit (Part No. 024705) and drain extension kit (Part No. 024710) available for using EF40 for combined 450mm + 600mm wide

EF30

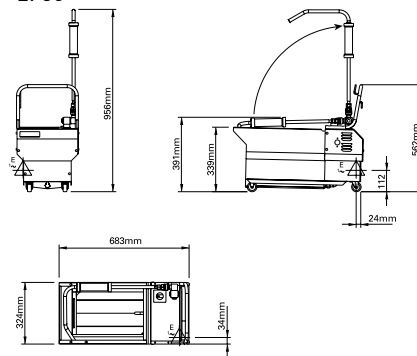

EF35

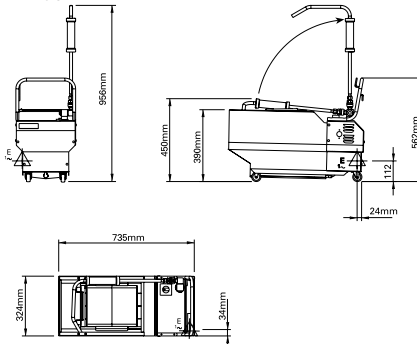

EF40

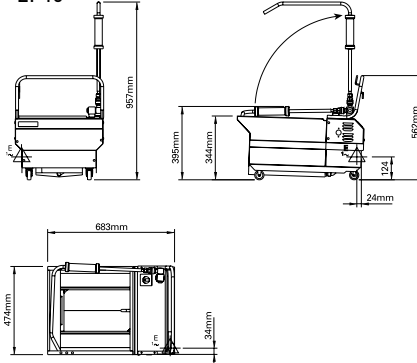

moffat.com.au

moffat.co.nz

Australia

moffat.com.au

Moffat Pty Limited

Victoria/Tasmania
740 Springvale Road
Mulgrave, Victoria 3170
Telephone +613-9518 3888
Facsimile +613-9518 3833
vsales@moffat.com.au

New South Wales
Telephone +612-8833 4111
nswsales@moffat.com.au
South Australia
Telephone +613-9518 3888
vsales@moffat.com.au

Queensland
Telephone +617-3630 8600
qldsales@moffat.com.au

Western Australia
Telephone +618-9413 2400
wasales@moffat.com.au

New Zealand

moffat.co.nz

Moffat Limited

Rolleston
45 Illinois Drive
Izone Business Hub
Rolleston 7675
Telephone +64 3-983 6600
Facsimile +64 3-983 6660
sales@moffat.co.nz

Auckland
Telephone +64 9-574 3150
sales@moffat.co.nz



In line with policy to continually develop and improve its products, Moffat Limited reserves the right to change specifications and design without notice.

© Copyright Moffat Ltd
AN.BSE.01.19/1620

an Ali Group Company



The Spirit of Excellence