

Modular Cooking Range Line EVO900 3 Drawer Refrigerated Base (R290)

ITEM # _____

MODEL # _____

NAME # _____

SIS # _____

AIA # _____



392601 (Z9TTAECOMKN) Refrigerated base with 3 drawers, -2/+10 C - R290

Short Form Specification

Item No. _____

Refrigerated base with 3 drawers. Built-in refrigerator compressor unit. Can operate over the temperature range of -2°C to 10 °C. Exterior panels in stainless steel. To be installed below other EVO900 top units. Delivered with 50 mm height adjustable feet.

Main Features

- Adjustable temperature range from -2 °C to +10 °C to suit meat, fish and dairy storage requirements.
- Anti-tilt runners accept GN 1/1 containers.
- Forced air circulation for rapid cooling and an even temperature distribution.
- Right angled side edges eliminate gaps and possible dirt traps between units.
- Unit delivered with 50 mm height adjustable feet in Stainless steel.
- Unit can be easily installed below other 900 line top models.
- Defrosting and automatic evaporation of condense drain: the condense is automatically evaporated thanks to the electric resistance in the condense drain container.
- Designed for modular installation into the cooking block.
- CFC and HCFC free (highly ecological refrigerant type: R290).

Construction

- Access to all components from the front.
- Built-in compressor to suit operating conditions.
- Exterior panels in Stainless steel with Scotch Brite finish to meet the highest hygiene standards.

Optional Accessories

- Flanged feet kit PNC 206136
- Frontal kicking strip for concrete installation, 1600 mm PNC 206152
- Frontal kicking strip, 1600 mm PNC 206179
- 2 drawers for refrigerated base PNC 206348
- Kit 3 base support for feet or wheels for refrigerated base or freezer base PNC 206430
- Kit 6 wheels - 3 swivelling with brake PNC 206432

APPROVAL: _____

Front

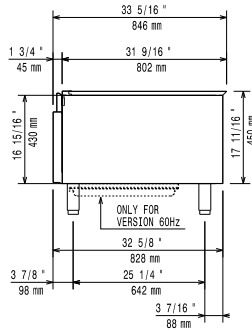

Side

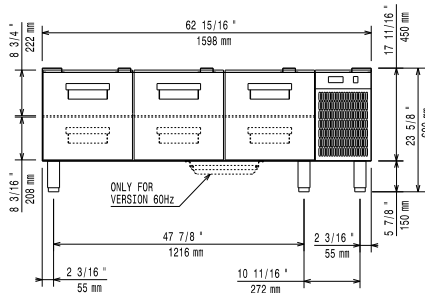

D = Drain
EI = Electrical inlet (power)

Top

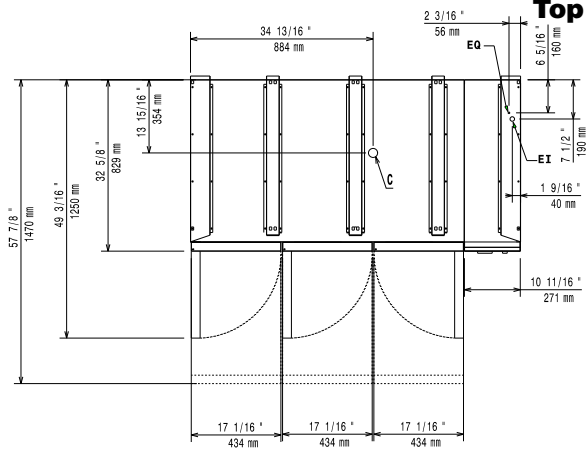

Electric

Supply voltage:
392601 (Z9TTAECOMKN) 220-230 V/1N ph/50 Hz
Electrical power max.: 0.44 kW
Total Watts: 0.44 kW

Key Information:

Gross capacity: 225 lt
External dimensions, Width: 1600 mm
External dimensions, Depth: 830 mm
External dimensions, Height: 600 mm
Net weight: 110 kg
Shipping weight: 146 kg
Shipping height: 820 mm
Shipping width: 1300 mm
Shipping depth: 1700 mm
Shipping volume: 1.81 m³

Sustainability

Refrigerant type: R290
Refrigerant weight: 85 g