

## Modular Cooking Range Line EVO900 Gas Solid Top on Gas Oven

ITEM # \_\_\_\_\_

MODEL # \_\_\_\_\_

NAME # \_\_\_\_\_

SIS # \_\_\_\_\_

AIA # \_\_\_\_\_



392264 (Z9STGH10GA)

Gas solid top (10,5 kW) on  
gas oven (8,5 kW) - (AGA)

### Short Form Specification

#### Item No. \_\_\_\_\_

High efficiency 10.5 kW central burner with flame failure device and protected pilot light. Large cooking surface with differentiated heating zones. Large flat cooking surface made in cast iron allows for the use of a number of various sized pots and pans, all easily moved across the surface without lifting. Oven chamber with 3 levels of runners to accommodate 2/1 GN shelves (2 steam pans). Ribbed, cast-iron oven base plate. Exterior panels in stainless steel. Worktop in 20/10, stainless steel. Right angled side edges eliminate gaps and possible dirt traps between units.

### Main Features

- Gas heated, 10.5 kW central burner, solid top.
- Durable cast iron cooking plate, easy to clean.
- The center of the plate can reach a maximum temperature of 500 °C while decreasing outwards.
- Central burner with optimized combustion, flame failure device and protected pilot light.
- Piezo ignition.
- Temperature gradients to satisfy different cooking needs, provided over the whole plate thanks to the temperature fine-tuning by zone.
- Various sizes of pans can be used at the same time due to large surface area with no intermediate sectors.
- Pans can easily be moved from one area to another without lifting.
- Base compartment consists of a gas heated standard oven with stainless steel burners and self stabilizing flame positioned beneath the base plate. Oven chamber to have 3 levels of runners to accommodate 2/1 GN shelves (2 steam pans) and ribbed cast iron base plate.
- Oven thermostat adjustable from 120 °C to 280 °C.
- All major compartments located in front of unit for ease of maintenance.
- IPX5 water resistance certification.
- The special design of the control knob system guarantees against water infiltration.

### Construction

- All exterior panels in Stainless Steel with Scotch Brite finishing.
- Model has right-angled side edges to allow flush fitting joints between units, eliminating gaps and possible dirt traps.
- Unit is 900mm deep to give a larger working surface area.

APPROVAL: \_\_\_\_\_

### Optional Accessories

- |  |            |                          |  |            |                          |
|--|------------|--------------------------|--|------------|--------------------------|
| • Junction sealing kit   | PNC 206086 | <input type="checkbox"/> | • 2 side covering panels, height 700 mm, depth 900 mm  | PNC 206335 | <input type="checkbox"/> |
| • Draught diverter, 150 mm diameter  | PNC 206132 | <input type="checkbox"/> | • Base support for feet or wheels - 800mm (EVO700/900) | PNC 206367 | <input type="checkbox"/> |
| • Matching ring for flue condenser, 150 mm diameter  | PNC 206133 | <input type="checkbox"/> | • Chimney grid net, 400mm                              | PNC 206400 | <input type="checkbox"/> |
| • 4 wheels, 2 swivelling with brake (EVO700/900). It is mandatory to install with base supports for feet/wheels. | PNC 206135 | <input type="checkbox"/> | • Pressure regulator for gas units                     | PNC 927225 | <input type="checkbox"/> |
| • Flanged feet kit   | PNC 206136 | <input type="checkbox"/> |  |            |                          |
| • Frontal kicking strip for concrete installation, 800 mm  | PNC 206148 | <input type="checkbox"/> |  |            |                          |
| • Frontal kicking strip for concrete installation, 1000 mm   | PNC 206150 | <input type="checkbox"/> |  |            |                          |
| • Frontal kicking strip for concrete installation, 1200 mm   | PNC 206151 | <input type="checkbox"/> |  |            |                          |
| • Frontal kicking strip for concrete installation, 1600 mm   | PNC 206152 | <input type="checkbox"/> |  |            |                          |
| • Pair of side kicking strips (concrete installation)  | PNC 206157 | <input type="checkbox"/> |  |            |                          |
| • Side handrail for right/left hand  | PNC 206165 | <input type="checkbox"/> |  |            |                          |
| • Frontal handrail 800 mm  | PNC 206167 | <input type="checkbox"/> |  |            |                          |
| • Frontal kicking strip, 800 mm  | PNC 206176 | <input type="checkbox"/> |  |            |                          |
| • Frontal kicking strip, 1000 mm   | PNC 206177 | <input type="checkbox"/> |  |            |                          |
| • Frontal kicking strip, 1200 mm   | PNC 206178 | <input type="checkbox"/> |  |            |                          |
| • Frontal kicking strip, 1600 mm   | PNC 206179 | <input type="checkbox"/> |  |            |                          |
| • Pair of side kicking strips  | PNC 206180 | <input type="checkbox"/> |  |            |                          |
| • 2 panels for service duct (single installation)  | PNC 206181 | <input type="checkbox"/> |  |            |                          |
| • Large handrail (portioning shelf) 800 mm   | PNC 206186 | <input type="checkbox"/> |  |            |                          |
| • Frontal handrail 1200 mm   | PNC 206191 | <input type="checkbox"/> |  |            |                          |
| • Frontal handrail 1600 mm   | PNC 206192 | <input type="checkbox"/> |  |            |                          |
| • 2 panels for service duct (back to back installation)  | PNC 206202 | <input type="checkbox"/> |  |            |                          |
| • 4 feet for concrete installation (not for 900 line freestanding grill)   | PNC 206210 | <input type="checkbox"/> |  |            |                          |
| • Flue condenser for 1 module, 150 mm diameter   | PNC 206246 | <input type="checkbox"/> |  |            |                          |
| • Water column with swivel arm (water column extension not included)   | PNC 206289 | <input type="checkbox"/> |  |            |                          |
| • Water column extension   | PNC 206290 | <input type="checkbox"/> |  |            |                          |
| • Chimney upstand, 800 mm  | PNC 206304 | <input type="checkbox"/> |  |            |                          |

**Front**

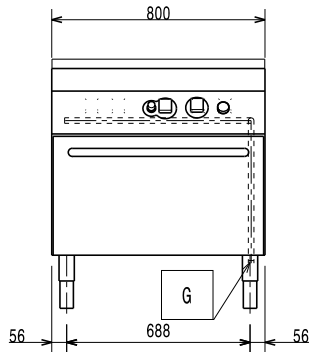

**Side**

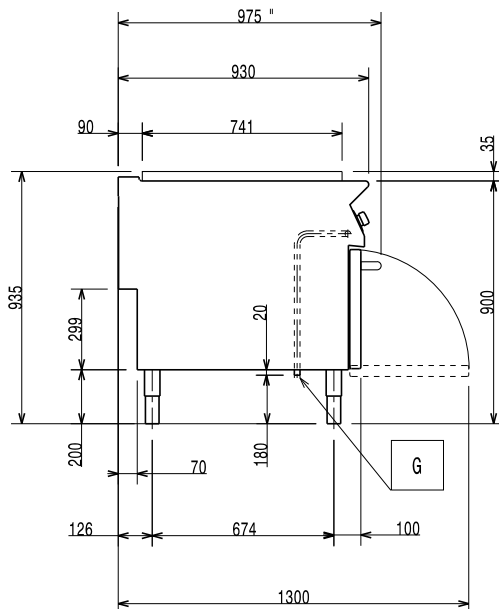

**EQ** = Equipotential screw  
**G** = Gas connection

**Top**

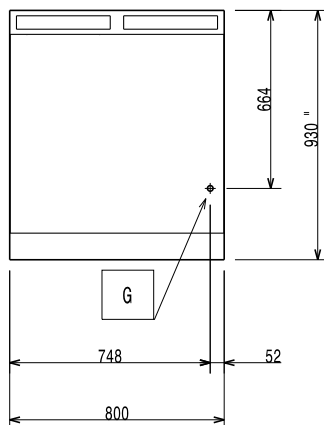

**Gas**

<b>Gas Power:</b>	<b>392264 (Z9STGH10GA)</b>	19 kW
<b>Standard gas delivery:</b>		Natural Gas G20 (20mbar)
<b>Gas Type Option:</b>		LPG; Natural Gas
<b>Gas Inlet:</b>		1/2"

**Key Information:**

<b>Solid top usable surface (width):</b>	795 mm
<b>Solid top usable surface (depth):</b>	696 mm
<b>Oven working Temperature:</b>	120 °C MIN; 280 °C MAX
<b>Oven Cavity Dimensions (width):</b>	575 mm
<b>Oven Cavity Dimensions (height):</b>	300 mm
<b>Oven Cavity Dimensions (depth):</b>	700 mm
<b>Net weight:</b>	171 kg
<b>Shipping weight:</b>	166 kg
<b>Shipping height:</b>	1090 mm
<b>Shipping width:</b>	1020 mm
<b>Shipping depth:</b>	880 mm
<b>Shipping volume:</b>	0.98 m <sup>3</sup>
<b>Certification group:</b>	N9TG

If appliance is set up or next to or against temperature sensitive furniture or similar, a safety gap of approximately 150 mm should be maintained or some form of heat insulation fitted.