

**Modular Cooking Range Line
EVO700 Electric Chip Scuttle**

ITEM # _____

MODEL # _____

NAME # _____

SIS # _____

AIA # _____



372086 (Z7CSPDC000) Electric Chip Scuttle

Short Form Specification

Item No. _____

Heating via infrared heating elements positioned on the back of the unit. Perforated false bottom GN 1/1 specially shaped for easier food collection. One piece pressed worktop in 1.5 mm thick stainless steel. Easy to use control panel with ON/OFF switch. Exterior panels in stainless steel with Scotch Brite finish. Right-angled side edges to allow flush-fitting junction between units.

Main Features

- Recommended for use next to a fryer to allow excess oil to drip in the well basin.
- Unit to have infrared heating elements positioned on the back of the unit to keep servings warm until ready to be plated and served.
- Well able to contain 1/1 GN container with a maximum height of 150 mm.
- Easy-to-use control panel.
- Unit supplied with a perforated GN 1/1 false bottom specially shaped for easier food collection.
- All major compartments located in front of unit for ease of maintenance.
- Suitable for countertop installation.

Construction

- One piece pressed 1.5 mm work top in Stainless steel.
- All exterior panels in Stainless Steel with Scotch Brite finishing.
- Model has right-angled side edges to allow flush fitting joints between units, eliminating gaps and possible dirt traps.
- IPx4 water protection.

Optional Accessories

- Junction sealing kit PNC 206086
- Support for bridge type installation, 800 mm PNC 206137
- Support for bridge type installation, 1000 mm PNC 206138
- Support for bridge type installation, 1200 mm PNC 206139
- Support for bridge type installation, 1400 mm PNC 206140
- Support for bridge type installation, 1600 mm PNC 206141
- Support for bridge type installation, 400 mm PNC 206154
- Frontal handrail 400 mm PNC 206166
- Frontal handrail 800 mm PNC 206167
- Large handrail (portioning shelf) 400 mm PNC 206185
- Large handrail (portioning shelf) 800 mm PNC 206186
- Frontal handrail 1200 mm PNC 206191
- Frontal handrail 1600 mm PNC 206192
- Right and left side handrails PNC 206240
- Chimney upstand, 400 mm PNC 206303
- 2 side covering panels, height 250 mm, depth 700 mm PNC 206320

APPROVAL: _____

Front

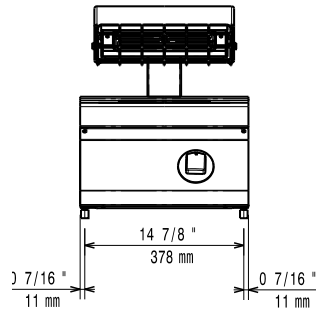

Side

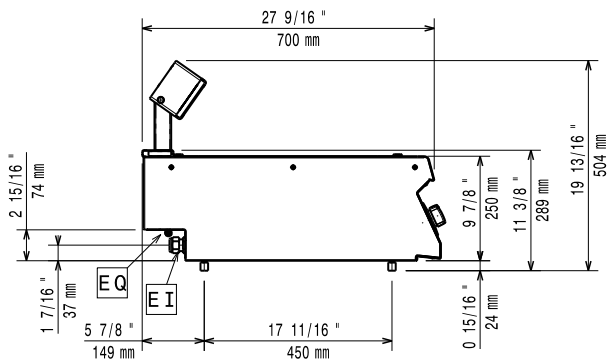

EQ = Electrical inlet (power)

Top

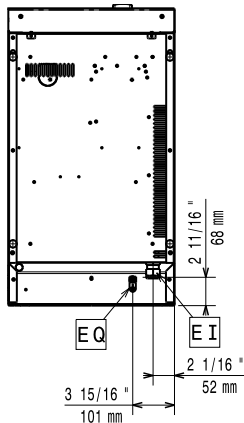

Electric

Supply voltage:	220-230 V/1 ph/50/60 Hz
372086 (Z7CSPDC000)	
Electrical power max.:	1 kW
Total Watts:	1 kW
Predisposed for:	220-230V 1~ 50/60Hz 0,9-1kW

Key Information:

Usable well dimensions (width):	306 mm
Usable well dimensions (height):	156 mm
Usable well dimensions (depth):	510 mm
Net weight:	20 kg
Shipping weight:	26 kg
Shipping height:	640 mm
Shipping width:	460 mm
Shipping depth:	820 mm
Shipping volume:	0.24 m ³

If appliance is set up or next to or against temperature sensitive furniture or similar, a safety gap of approximately 150 mm should be maintained or some form of heat insulation fitted.

Certification group: ECS7