



Eswood

Professional

Warewasher

UC25NDP

Professional Undercounter Warewasher



Eswood

Recirculating Undercounter Warewasher

UC25NDP is a compact recirculating dishwasher that suits all popular wash rack sizes. It is a fully automatic operation with a simple 'start' button after selecting the wash cycle.

Upper and lower wash arms with multiple jets has been designed to ensure maximum wash and rinse coverage. The boost heater is thermostatically controlled and interlocked to machine operation to ensure correct sanitising every time.

New is the drain pump, detergent pump and rinse aid injector fitted as standard. All new digital wash & rinse temperature displays for easy temperature recording in controlled environments.

The UC25NDP conforms to the highest of health and sanitary standards, meeting FSANZ safe food codes and certifications in HACCP and WaterMark.

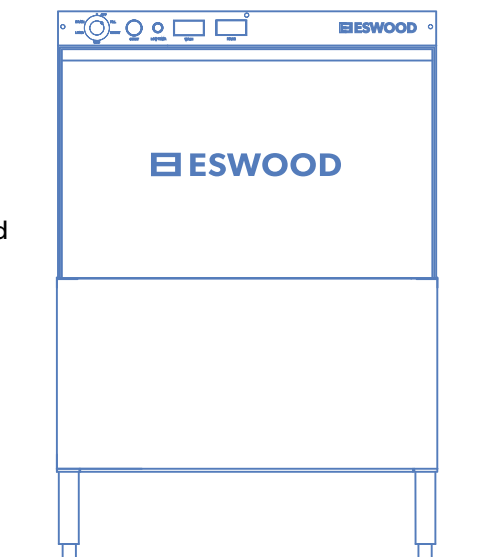



Up to 500 plates per hour

Full width tank strainers and dual filtration

3 Wash programs to match degree of soil

Durable stainless-steel body construction and wash arms

Integrated drain pump as standard

Detergent pump and Rinse aid injector as standard

Safety cut-off fitted to door

Easily removable spray arms and filters

Accommodates 500 x 500 mm baskets

Accurate Digital wash & rinse temperature controllers and displays

- A. Drain connection 25mm OD x 20mm ID at 1.8m hose
 B. Hot Water Connection 3/4" BSP x 1.5m braided hose
 C. Electrical connection 2m 240V 15A plug

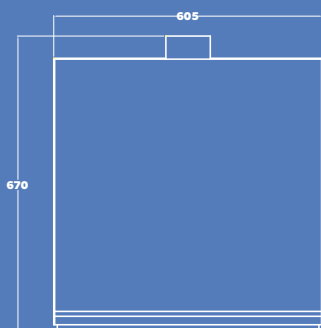
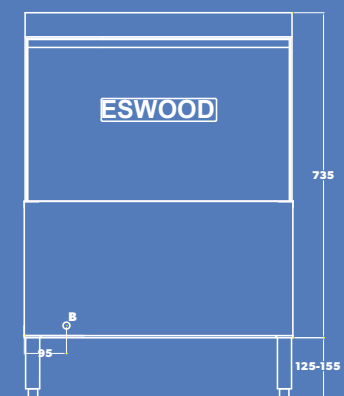
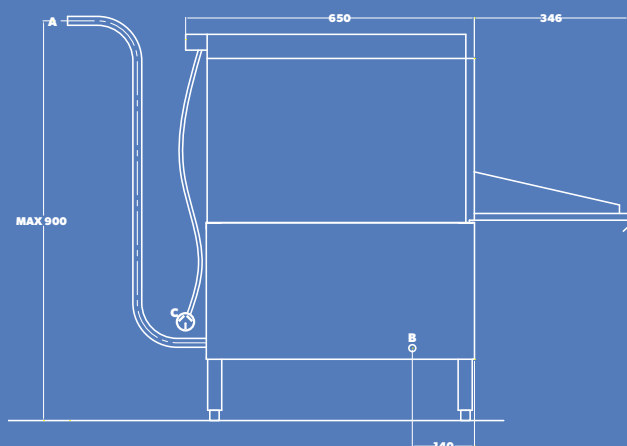

UC25NDP

Professional Undercounter Warewasher

UC25NDP Specifications

DIMENSIONS (WxDxH)	605 x 670 x 875 mm
DEPTH WITH DOOR OPEN	1000 mm
RACK SIZE – G74N (WxD)	500 x 500 mm
WEIGHT	68 kg
ELECTRIC CONNECTION	15A Single Phase - 240V
RATING	3.6 kW
WATER SUPPLY	65°C / 2-4 bar (28-58 psi)
PACKED	0.3m ³
MEAL SERVICE	30 – 60 pax
WASH CYCLE	60 sec 85 sec 115 sec
DETERGENT PUMP	Fitted
RINSE AID INJECTOR	Fitted
DRAIN PUMP	Fitted
WATER CONSUMPTION	3.5L Hot Cycle
TANK CAPACITY	18L
WATERMARK APPROVAL	WM-022833
HACCP APPROVAL	PE-388-GE-09

Dimensions may change without notice in accordance with product development and design

Proudly Distributed By

middleby.com.au

211-217 Woodpark Road SMITHFIELD NSW 2164

T: 1800 013 123

E: sales@middleby.com.au

ESWOOD

MIDDLEBY AUSTRALIA