



Eswood

Professional

Warewasher

B42PN

Professional Undercounter Warewasher



Eswood

Recirculating Undercounter Warewasher

B42PN is a compact recirculating undercounter dishwasher. It has fully automatic operation with a simple 'start' button after selecting the wash cycle.

Upper and lower wash arms with multiple jets has been designed to ensure maximum wash and rinse coverage. The boost heater is thermostatically controlled and interlocked to machine operation to ensure correct sanitising every time.

All new digital wash & rinse temperature displays for easy temperature recording in controlled environments. Drain pump, detergent pump and rinse aid injector fitted as standard.

The B42PN conforms to the highest of health and sanitary standards, meeting FSANZ safe food codes and certifications in HACCP and WaterMark.

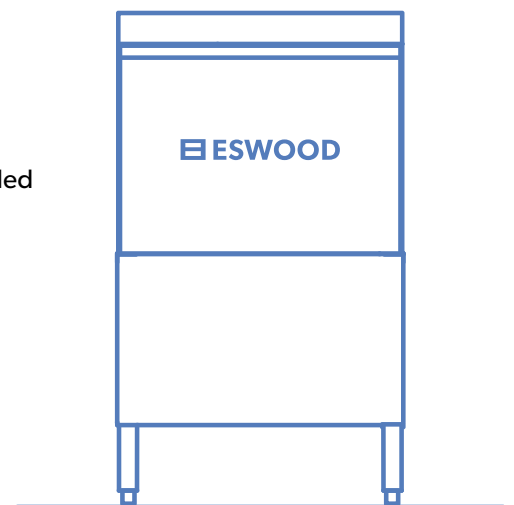



Up to 1200 pieces per hour

Durable stainless-steel body construction and wash arms

Accurate digital wash and rinse temperature controllers and displays

Integrated drain pump as standard

Detergent pump and rinse aid injector as standard

Safety cut-off fitted to door

3 Wash programs to match degree of soil

Easily removable spray arms and filters

Supplied with 400 x 400 (14" x 14") flat rack, plate/saucer support and cutlery basket

- A. Drain connection 25mm OD x 20mm ID at 1.8m drain hose
 B. Hot Water Connection 3/4" BSP x 1.5m braided hose
 C. Electrical connection 2m 15A plug

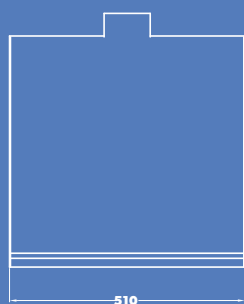
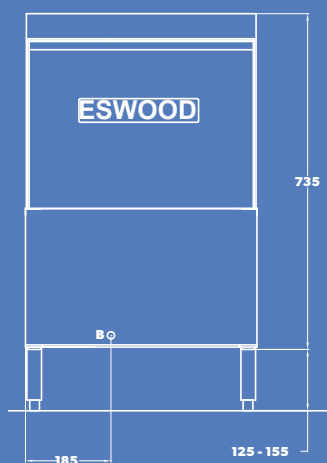
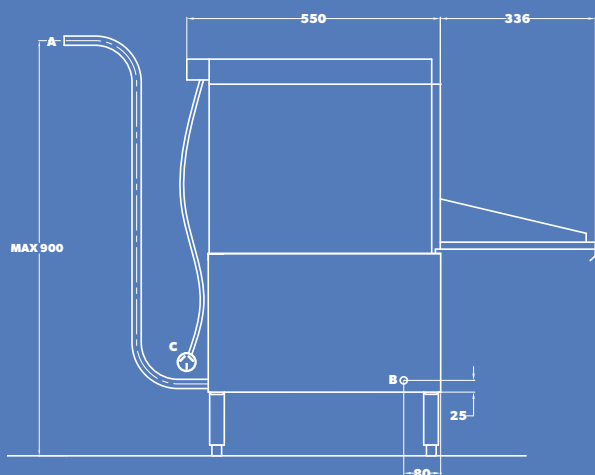

B42PN

Professional Undercounter Warewasher

B42PN Specifications

DIMENSIONS (WxDxH)	510 x 550 x 875 mm
DEPTH WITH DOOR OPEN	890 mm
RACK SIZE (WxD)	400 x 400 mm
WEIGHT	50 kg
ELECTRIC CONNECTION	15A Single Phase, 240V
RATING	3.4 kW
WATER SUPPLY	65°C / 2-4 bar (28-58 psi)
PACKED	0.2 m ³
MEAL SERVICE	30 light meals
WASH CYCLE	60 sec 90 sec 120 sec
DETERGENT PUMP	Fitted
RINSE AID INJECTOR	Fitted
DRAIN PUMP	Fitted
WATER CONSUMPTION	3L cycle
TANK CAPACITY	13L
WATERMARK APPROVAL	WM-022833
HACCP APPROVAL	PE-388-GE-09

Dimensions may change without notice in accordance with product development and design

Proudly Distributed By

middleby.com.au

211-217 Woodpark Road SMITHFIELD NSW 2164

T: 1800 013 123

E: sales@middleby.com.au