

Technical data sheet for

H8D-FS-UC HOLDING CABINET - FULL SIZE

8 Tray Electric Undercounter Holding Cabinet DIGITAL CONTROL



STANDARD FEATURES

- Undercounter 810mm unit height
- Designed for individual use or system installed with Turbofan E32D Convection Ovens
- 8 full size 460mm x 660mm / 18" x 26" sheet pan capacity
- 74mm tray spacing
- Compact 735mm width
- 220-240V plug-in 10A cordset fitted
- 1900W cabinet heating
- Full double skin construction
- Digital display Temperature and Timer controls
- Large easy view 20mm high displays
- Electronic temperature control
- 3 hold timers
- Continuous door seal
- Low velocity circulation fan system
- Dual halogen cabinet interior lamps
- Cabinet drain to condensate pan
- 4 dia. 65mm castors with 2 front castors with wheel and swivel lock, 2 rigid rear castors
- 100% recyclable packaging



H8D-FS-UC

Unit shall be a Moffat electrically heated Turbofan Undercounter Holding Cabinet. NSF.4 listed. The holding cabinet shall have double skin construction with stainless steel interior and exterior sides, front and top. Door shall be side hinged. Unit shall have capacity for 8 full size 460mm x 660mm / 18" x 26" sheet pans. A single speed fan shall gently and evenly circulate air around the cabinet. Cabinet shall be controlled by a Digital display electronic Temperature and Timer controller. 3 hold timers shall be standard. Holding cabinet shall be mounted on castors, with two rigid castors at rear and two castors, swivel and wheel lock at front. Holding Cabinet shall be fitted with a 10A cordset. Unit shall be supplied in 100% recyclable shipping packaging.

H8D-FS-UC 8 Tray Electric Full Size Undercounter Holding Cabinet DIGITAL CONTROL

CONSTRUCTION

304 stainless steel interior cabinet
Stainless steel front, sides and top exterior
Stainless steel interior side racks
Stainless steel frame, side hinged door
5mm thick door glass
Stainless steel control panel
Aluminised coated steel rear panels
Stainless steel base

CONTROLS

Electronic controls with Digital Time and Temperature displays
Large 20mm high LED displays
ON/OFF key
Cabinet lamp key
Temperature set and actual key
3 timer keys
Timer range up to 4 hours
Timers countdown or count-up modes
Temperature range 20- 90°C

CLEANING

Stainless steel top and side exterior panels
Removable plug-in oven door seal (no tools required)

SPECIFICATIONS

Electrical Requirements
220-240V, 50Hz, 1-phase, 2.05kW, 8.5A
220-240V, 60hz, 1 phase, 2.05kW, 8.5A
10A cordset fitted

External Dimensions

Width 735mm
Height 810mm including dia. 65mm castors
Depth 810mm

Nett Weight

81kg

Packing Data

99kg
0.80m³
Width 780mm
Height 1080mm
Depth 960mm

INSTALLATION CLEARANCES

Rear 25mm
LH Side 0mm
RH Side 0mm

CLEARANCE FROM SOURCES OF HEAT

A minimum distance of 300mm from the appliance sides is required



Australia
www.moffat.com.au
New Zealand
www.moffat.co.nz
www.turbofanoven.com

Australia
Moffat Pty Limited

Victoria/Tasmania
740 Springvale Road
Mulgrave, Victoria 3170
Telephone +61 3-9518 3888
Facsimile +61 3-9518 3833
vsales@moffat.com.au

New South Wales
Telephone +61 2-8833 4111
nswsales@moffat.com.au

South Australia
Telephone +61 3-9518 3888
vsales@moffat.com.au

Queensland
Telephone +61 7-3630 8600
qldsales@moffat.com.au

Western Australia
Telephone +61 8-9413 2400
wasales@moffat.com.au

New Zealand
Moffat Limited

Christchurch
45 Illinois Drive
Izone Business Hub
Rolleston 7675
Telephone +64 3-983 6600
Facsimile +64 3-983 6660
sales@moffat.co.nz

Auckland
Telephone +64 9-574 3150
sales@moffat.co.nz



Designed and manufactured by



ISO9001

All Turbofan products are designed and manufactured by Moffat using the internationally recognised ISO9001 quality management system, covering design, manufacture and final inspection, ensuring consistent high quality at all times.

In line with policy to continually develop and improve its products, Moffat Limited reserves the right to change specifications and design without notice.

© Copyright Moffat Ltd
AN.TFN.S.1901

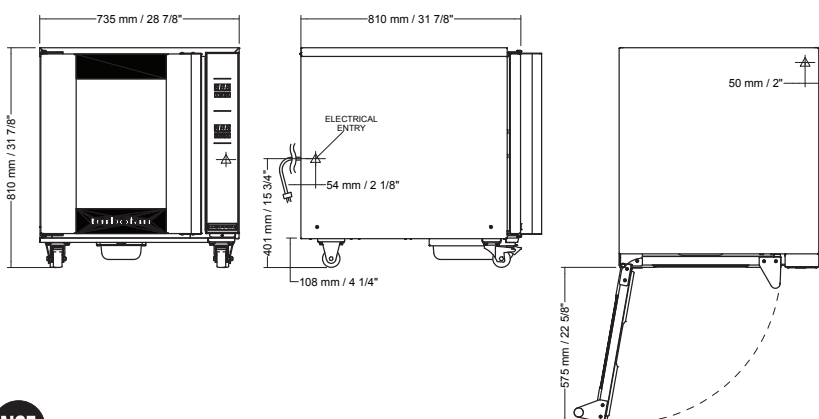

an Ali Group Company



The Spirit of Excellence