

Technical data sheet for

E27D2 ON THE SK2731N / SK2731U STAND

Full Size Digital / Electric Convection Oven
on a Stainless Steel Stand



E27D2

Unit shall be a Moffat electrically heated Turbofan convection oven. The oven shall have a one piece vitreous enamel oven chamber, stainless top and sides and safe touch vented easy clean drop down door. Oven shall have capacity for two full size sheet pans. The oven shall have 2.8kW heating elements. The oven shall have a bi-directional single reversing fan system and feature a single halogen oven lamp. The oven shall be controlled by an electronic control having separate digital displays and adjusting knobs for time and temperature functions. The oven control shall allow both manual and programmed operating modes with programmable steam injection and 3 stage cooking. Oven shall be able to be bench mounted on 76mm feet or mounted on oven stand models SK2731N or SK2731U. Oven shall be fitted with a 15A plug-in cordset. Unit shall be supplied in 100% recyclable shipping packaging.

SK2731N

Unit shall be a Moffat Turbofan stainless steel oven stand. The stand shall be constructed from stainless steel tube with castors, with front castors having dual swivel and wheel locks. It shall be fitted with 6 tray runners suitable for up to 600 x 400 trays and GN 1/1 pans. The stand shall be fully compatible with, and support, Turbofan Convection Oven models E27, E28, and E31. Unit shall be supplied in 100% recyclable shipping packaging.

SK2731U

Unit shall be a Moffat Turbofan stainless steel oven stand. The stand shall be constructed from stainless steel tube with castors, with front castors having dual swivel and wheel locks. It shall be fitted with 6 tray runners suitable for up to 12 half size sheet pans or 6 full size sheet pans. The stand shall be fully compatible with, and support, Turbofan Convection Oven models E27, E28, and E31. Unit shall be supplied in 100% recyclable shipping packaging.

STANDARD FEATURES

- 2 460mm x 660mm / 18" x 26" full size sheet pan capacity
- 2 400mm x 600mm tray capacity
- 115mm tray spacing
- Compact 810mm width
- Digital display Time and Temperature controls
- Large easy view ¾" / 20mm high displays
- Electronic thermostat control
- Electronic timer
- Manual mode and Program mode
- 20 programs with 3 stage cooking and stage end alarms
- Steam injection mode and manual injection
- Bi-directional reversing fan system
- 2.8kW heating power
- 15A plug-in cordset fitted
- Vitreous enamel oven chamber
- Plug-in continuous oven door seal
- Safe-Touch vented drop down door
- Stay-Cool door handle
- Heavy-duty door hinges
- Easy clean door glass system
- Dual halogen oven lamps
- Dia. 180mm full stainless steel oven fan
- Anti-skid 50mm dia. 76mm high adjustable stainless steel feet
- 2 oven wire racks supplied
- 100% recyclable packaging

ACCESSORIES

- Turbofan SK2731N Oven Stand suits 400mm x 600mm trays and GN 1/1 pans
- Turbofan SK2731U Oven Stand suits 460mm x 660mm / 18" x 26" pans

E27D2 Full Size Digital / Electric Convection Oven on a Stainless Steel Stand

CONSTRUCTION

Vitreous enameled fully welded oven chamber
Stainless steel front, sides and top exterior
Stainless steel oven fan baffle and oven vent
Removable 2 position chrome plated wire side racks
Oven racks chrome plated wire (2 supplied)
Stainless steel frame drop down hinged door
5mm thick door outer glass
5mm thick low energy loss door inner glass
Heavy-duty counterbalanced door hinges
Wear resistant powder coated welded door handle
Stainless steel control panel
Aluminised coated steel base and rear panels

CONTROLS

Electronic controls with Digital Time and Temperature display,
Manual or Program modes
Large 20mm high LED displays
Two individual time and temperature setting control knobs
ON/OFF and Oven Lights key
Timer Start/Stop key
Steam injection key
Programs select key
Actual temperature display key
Adjustable buzzer/alarm volume
Thermostat range 50-260°C
Timer range from 180 minutes in countdown mode
Timer range up to 999 minutes in time count mode for holding, slow cooking
Over-temperature safety cut-out

CLEANING

Stainless steel top and sides continuous exterior panel
Vitreous enameled oven chamber
Fully removable chrome plated oven side racks
Removable stainless steel oven fan baffle
Full stainless steel oven fan
Easy clean door system with hinge out door inner glass (no tools required)
Removable plug-in oven door seal (no tools required)
76mm high stainless steel feet for easy access underside

SPECIFICATIONS

Electrical Requirements
230-240V, 50Hz, 1P+N+E, 3kW, 12A
15A cordset fitted
Water Requirements (optional)
Cold water connection ¾" BSP male
80psi maximum inlet pressure / 20psi minimum inlet pressure

External Dimensions

Width 810mm
Height 607mm including 76mm feet
Depth 762mm

Oven Internal Dimensions

Width 695mm
Height 305mm
Depth 470mm
Volume 0.10m³

Oven Rack Dimensions

Width 660mm
Depth 460mm

Nett Weight (E27D2)
60.2kg

Packing Data (E27D2)

77.8kg
0.55m³

Width 870mm
Height 755mm
Depth 835mm

SK2731N / U Stainless Steel Stand

All stainless steel welded frame oven stand for Turbofan E27, E28 and E31 Series model ovens
6 position tray runners standard
4 76mm diameter wheel swivel castors standard with 2 front castors with dual swivel and wheel lock
Welded 38mm and 32mm square tube front and rear frames
Welded rack supports/side frames
Top frame oven supports suit Turbofan E27, E28 and E31 Series oven mounting
Supplied CKD for assembly on site

External Dimensions (SK2731N/U Oven Stand)

Width 810mm
Height 880mm
Depth 2650mm

Nett Weight (SK2731N/U Oven Stand)

19.5kg

Packing Data (SK2731N/U Oven Stand)

22kg
0.11m³
Width 830mm
Height 900mm
Depth 152mm

INSTALLATION CLEARANCES

Rear 25mm
LH Side 25mm
RH Side 25mm

CLEARANCE FROM SOURCES OF HEAT

A minimum distance of 300mm from the appliance sides is required

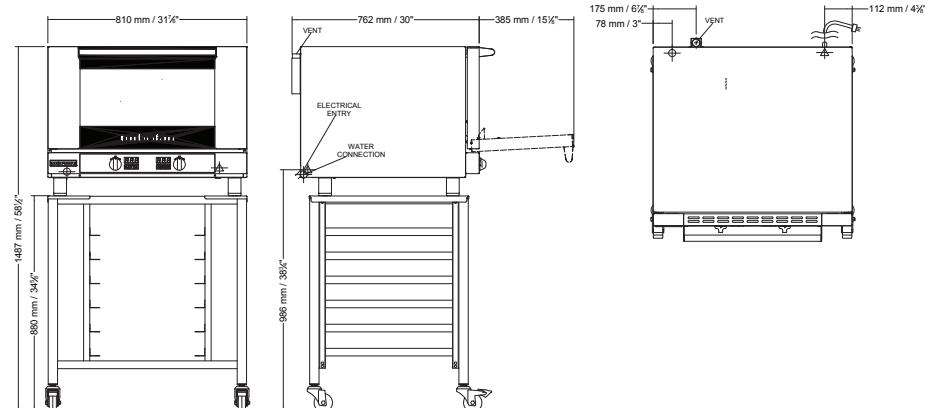

Australia
www.moffat.com.au
New Zealand
www.moffat.co.nz
www.turbofanoven.com

Australia
Moffat Pty Limited
Victoria/Tasmania
740 Springvale Road
Mulgrave, Victoria 3170
Telephone +61 3-9518 3888
Facsimile +61 3-9518 3833
vsales@moffat.com.au
New South Wales
Telephone +61 2-8833 4111
nswsales@moffat.com.au

South Australia
Telephone +61 3-9518 3888
vsales@moffat.com.au
Queensland
Telephone +61 7-3630 8600
qldsales@moffat.com.au
Western Australia
Telephone +61 8-9413 2400
wasales@moffat.com.au

New Zealand
Moffat Limited
Christchurch
45 Illinois Drive
Izone Business Hub
Rolleston 7675
Telephone +64 3-983 6600
Facsimile +64 3-983 6660
sales@moffat.co.nz
Auckland
Telephone +64 9-574 3150
sales@moffat.co.nz



Designed and manufactured by
MOFFAT

ISO9001
All Turbofan products are designed and manufactured by Moffat using the internationally recognised ISO9001 quality management system, covering design, manufacture and final inspection, ensuring consistent high quality at all times.

In line with policy to continually develop and improve its products, Moffat Limited reserves the right to change specifications and design without notice.

© Copyright Moffat Ltd
AN.TFN.S.1901

an Ali Group Company



The Spirit of Excellence