

Target Top Gas Static Oven Range 900mm

RNLB8110G



- Heavy-duty cast iron top with removable centre ring
- Matched modular height machined top for seamless work surface
- High output dual ring cast iron burner
- GN 2/1 gas static oven
- Drop down door
- Stainless steel exterior
- Black vitreous enamel finish to front panels
- Easy clean
- Easy service
- Fully modular

OVERALL CONSTRUCTION

- Galvanized steel chassis
- Welded hob with 1.5mm 304 stainless steel bull nose
- Splashback and hob sides 1.2mm 304 stainless steel
- Front panels and oven sides 0.9mm 304 stainless steel
- 150mm legs in 63mm dia. heavy-duty 1.2mm 304 stainless steel with adjustable feet

TARGET TOP

- 3 piece heavy-duty cast iron top with fully machined surface
- Top plates and removable centre with integral spill protection design
- Cast top reinforced with integral heat fins for heat zone definition
- 45MJ dual ring cast iron burner with single control
- Full pilot and flame failure protection
- 50mm thick refractory brick lined burner box for high heat retention
- Stainless steel spill tray
- Supplied with heavy-duty centre casting removal tool

OVEN

- Fully welded and vitreous enamelled oven liner
- GN 2/1 capacity with 4 position racking
- Heavy-duty easy remove heavy wire chrome rack supports
- Cast iron even heat oven sole plate
- 30MJ oven burner
- Pilot and flame failure with piezo ignition
- Welded frame drop down door with heavy-duty spring hinge system
- 0.9mm 304 stainless steel door outer
- 1.0mm press formed vitreous enamelled door inner
- High density fibreglass insulated
- Stay cool stainless steel door handle with cast metal handle mounts
- Supplied with two chrome wire oven racks

CONTROLS

- Large easy use control knob - heat resistant reinforced
- Easy view control settings on knob

TARGET TOP

- Variable high to low burner control
- Single control knob for burner and pilot system
- Flame failure pilot burner
- Manual pilot ignition for reliable operation

OVEN

- 80-300°C thermostatic control
- Piezo ignition to pilot burner
- Flame failure

CLEANING AND SERVICING

- Removable oven racking and sole plate
- Easy clean vitreous enamel oven and door inner
- Easy clean stainless steel exterior
- Target Top fully serviceable from front of unit
- Bottom sill removable for burner and pilot access
- Door hinge spring adjustable on unit (door outer removed)
- Door disengages for lift off removal and increased service access
- All parts front accessible from installed position

Series Options

RNLB - Low back models

RNB - 215mm splashback option

Waldorf Bold

Target Top Gas Static Oven Range 900mm

RNLB8110G

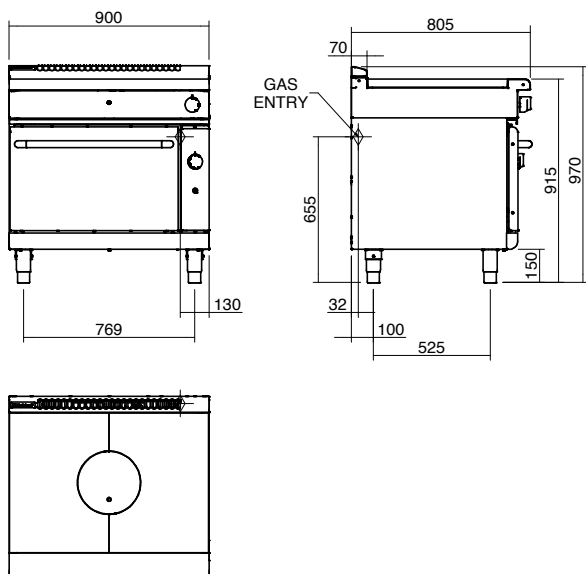

SPECIFICATIONS

Burners

45MJ dual ring cast iron - Target Top

30MJ tubular - Oven

Gas power (gross)

75MJ/hr, 20.8kW

Target Top

Cooking surface 900mm x 625mm, 5625cm²

Centre 280mm diameter

Maximum plate temperature at centre 500°C

Oven Dimensions

Width 665mm

Depth 590mm

Height 385mm

Rack size 660mm x 540mm

Rack positions 4

Gas connection

R ¾ (BSP) male

130mm from RH side, 32mm from rear,
and 655mm from floor

Optional underside connection (refer
specification drawing)

All units supplied with Natural and LP gas
regulator

Dimensions

Width 900mm

Depth 805mm

Height 915mm

Incl. low back 970mm

Incl. splashback 1130mm

Nett weight

259kg

Packing data

1.03m³, 324kg

Width 945mm

Depth 870mm

Height 1255mm

Gas types

Available in Natural gas and LP gas

Please specify when ordering

Units supplied complete with gas type
conversion kits

Other gas types on request

OPTIONS AT EXTRA COST

Joining caps

Castors

Plinth mounting

MOFFAT

moffat.com.au

moffat.co.nz

Australia

moffat.com.au

Moffat Pty Limited

Victoria/Tasmania
740 Springvale Road
Mulgrave, Victoria 3170
Telephone +613-9518 3888
Facsimile +613-9518 3833
vsales@moffat.com.au

New South Wales
Telephone +612-8833 4111
nswsales@moffat.com.au

South Australia
Telephone +613-9518 3888
vsales@moffat.com.au

Queensland
Telephone +617-3630 8600
qldsals@moffat.com.au

Western Australia
Telephone +618-9413 2400
wasales@moffat.com.au

New Zealand

moffat.co.nz

Moffat Limited

Rolleston
45 Illinois Drive
Izone Business Hub
Rolleston 7675
Telephone +64 3-983 6600
Facsimile +64 3-983 6660
sales@moffat.co.nz

Auckland
Telephone +64 9-574 3150
sales@moffat.co.nz



ISO9001
Quality
Management
Standard

Designed and manufactured by



ISO9001

All Waldorf Bold products are designed
and manufactured by Moffat using the
internationally recognised ISO9001 quality
management system, covering design,
manufacture and final inspection, ensuring
consistent high quality at all times.

In line with policy to continually develop
and improve its products, Moffat
Limited reserves the right to change
specifications and design without notice.

© Copyright Moffat Ltd
AN.WBD.S.02.19

an Ali Group Company



The Spirit of Excellence