

Technical data sheet for

GAS GRIDDLE ELECTRIC CONVECTION OVEN RANGE 1200mm

GP8121GEC



- Heavy-duty thermostatic gas griddle
- 20mm thick griddle plate
- Ribbed plate options
- Chromed mirror plate options
- Top weld sealed plates
- 31kW thermostatic griddle burner system
- Separate left, centre, and right heat zones
- GN 2/1 6.6kW electric convection oven
- Drop down door
- Storage cabinet on RH side
- Stainless steel exterior
- Easy clean
- Easy service
- Fully modular
- Low back model (GPL) available

Overall Construction

- Galvanized steel chassis
- Welded hob with 1.5mm 304 stainless steel bull nose
- Splashback and hob sides 1.2mm 304 stainless steel
- Front panels and oven sides 0.9mm 304 stainless steel
- Full 0.9mm stainless steel storage cabinet on right hand side
- 150mm legs in 63mm dia. heavy-duty 1.2mm 304 stainless steel with adjustable feet

GRIDDLE

- 20mm thick machined top plates standard
- Optional ribbed plate sections
- Optional mirror finish hard chrome plates
- 2.5mm thick 304 stainless steel splash guards sides and rear
- 2.0mm thick grease channel
- Three 10.3kW 3 bar even heat burners with three thermostatic controls
- Full pilot and flame failure protection with piezo ignition
- Stainless steel grease drawer
- Overlapping finish at front and rear of plate for easy clean

OVEN

- Fully welded and vitreous enamelled oven liner
- GN 2/1 capacity with 4 position racking
- Heavy-duty easy remove heavy wire chrome rack supports
- Cast iron even heat oven sole plate
- 6.5kW heating elements
- 100W heavy-duty motor
- 200mm diameter heavy-duty circulation fan
- Welded frame drop down door with heavy-duty spring hinge system
- 0.9mm 304 stainless steel door outer
- 1.0mm press formed vitreous enamelled door inner
- High density fibreglass insulated
- Stay cool stainless steel door handle with cast metal handle mounts
- Supplied with two chrome wire oven racks

Controls

- Large easy use control knob - heat resistant reinforced
- Easy view control settings on knob

GRIDDLE

- Separate left, centre and right side heat zones
- Three 90-300°C thermostats
- Flame failure pilot burners
- Piezo ignition to each pilot burner

OVEN

- Separate temperature and top heat power regulation controls
- 50-320°C thermostatic control
- Lo-Hi top heat control
- Indicator lights for power and heating

Cleaning and Servicing

- All models with easy clean stainless steel external finish
- Plate is finished front and rear with overlap construction to remove cleaning traps
- Control service and gas conversion through front of unit
- Burner service requires plate removal
- Removable oven racking and sole plate
- Easy clean vitreous enamel oven and door inner
- Door hinge spring adjustable on unit (door outer removed)
- Door disengages for lift off removal and increased service access
- Access to all parts from front of unit

Technical data sheet for

GAS GRIDDLE ELECTRIC CONVECTION OVEN RANGE 1200mm

GP8121GEC

Specifications

Burners

Three 10.3kW 3 bar chromed steel burners
- Griddle

Individual pilot, flame failure and piezo ignition

Oven Elements

4.5kW bottom heat element
2.0kW top heat element

Oven Fan Motor

100W

Gas power

31kW, 105,700 Btu/hr

Electrical requirements

6.6kW

1 phase connection:

230-240Vac, 50/60hz, 1P+N+E, 27.7A

3 phase connection:

400-415Vac, 50/60hz, 3P+N+E

L1 9.4A

L2 9.4A

L3 9.0A

Plate

Cooking surface 1192mm x 530mm, 6318cm²

Oven Dimensions

Width 665mm

Depth 590mm

Height 385mm

Rack size 660mm x 540mm

Rack positions 4

Gas connection

R ³/₄ (BSP) male

130mm from RH side, 32mm from rear,
and 655mm from floor

Optional underside connection
(refer specification drawing)

All units supplied with Natural and LP gas
regulator

Electrical connection

369mm from RH side, 484mm from rear, and
150mm from floor

DIMENSIONS

Width 1200mm

Depth 805mm

Height 915mm

Incl. low back 970mm

Incl. splashback option 1130mm

NETT WEIGHT

220kg

PACKING DATA

1.36m³, 300kg

Width 1245mm

Depth 870mm

Height 1255mm

GAS TYPES

Available in Natural gas and LP gas

Please specify when ordering

Units supplied complete with gas type
conversion kits

Other gas types on request

OPTIONS AT EXTRA COST

Joining caps

Castors

Plinth mounting

Ribbed plate options

Chrome plate options

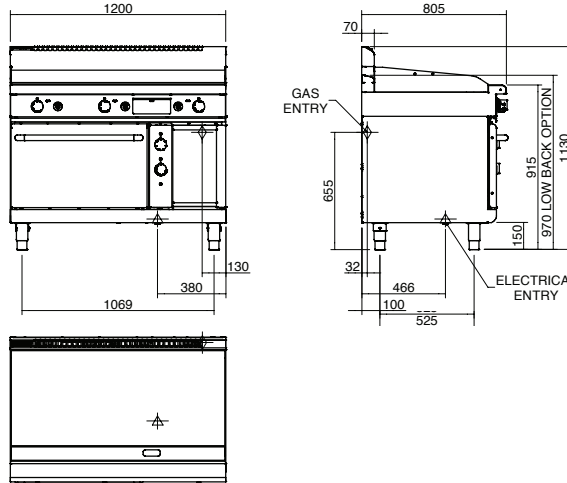

moffat.com.au

moffat.co.nz

Australia

Moffat Pty Limited

Victoria/Tasmania
740 Springvale Road
Mulgrave, Victoria 3170
Telephone +613-9518 3888
Facsimile +613-9518 3833
vsales@moffat.com.au

New South Wales
Telephone +612-8833 4111
nswsales@moffat.com.au

South Australia
Telephone +613-9518 3888
vsales@moffat.com.au

Queensland
Telephone +617-3630 8600
qldsales@moffat.com.au

Western Australia
Telephone +618-9413 2400
wasales@moffat.com.au

New Zealand

Moffat Limited

Rolleston
45 Illinois Drive
Izone Business Hub
Rolleston 7675
Telephone +64 3-983 6600
Facsimile +64 3-983 6660
sales@moffat.co.nz

Auckland
Telephone +64 9-574 3150
sales@moffat.co.nz



Designed and manufactured by



ISO9001

All Waldorf800 products are designed
and manufactured by Moffat using the
internationally recognised ISO9001
quality management system, covering
design, manufacture and final
inspection, ensuring consistent high
quality at all times.

In line with policy to continually develop
and improve its products, Moffat
Limited reserves the right to change
specifications and design without notice.



Cert. No. 7088

© Copyright Moffat Ltd
AN.W8.S.01.19

an Ali Group Company



The Spirit of Excellence