

Bench Top 600mm

BTLB8600-CD, BTLB8600-LS



BTLB8600-CD

OVERALL CONSTRUCTION

WORK BENCH

- 3.5mm thick compound work surface
 - 1.5mm 304 stainless steel top
 - 2.0mm galvanised steel backing
- Welded 1.5mm stainless steel bull nose
- Splashback and side panels 1.2mm stainless steel

CABINET BASE (SUPPLIED AS -CD MODEL)

- Modular for suite matched finish
- Double skin 0.9mm stainless steel interior and exterior
- GN 1/1 4 position racking kit
- 63mm dia. heavy-duty 1.2mm stainless steel legs with adjustable feet

LEG STAND (SUPPLIED AS -LS MODEL)

- Modular for suite matched finish
- 63mm dia. heavy-duty 1.2mm stainless steel legs with adjustable feet
- Framed stand shelf with 0.9mm stainless steel finish
- Quick assembly design (no tools required)

- Heavy-duty construction
- Cabinet Base or Leg Stand
- Stainless steel exterior
- Black vitreous enamel finish to front panels
- Easy clean
- Fully modular

Series Options

BTLB - Low back models

BTB - 215mm splashback option

Waldorf Bold

Bench Top 600mm

BTLB8600-CD

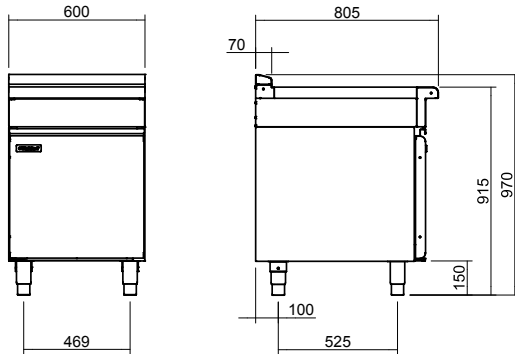

BTLB8600-LS

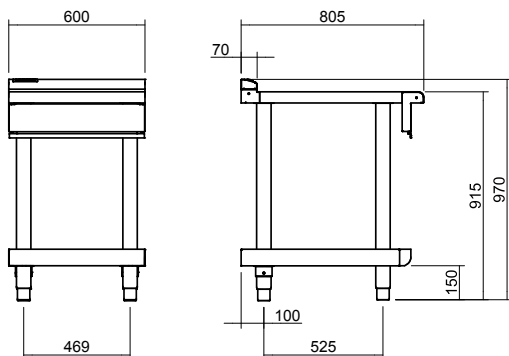

BTLB8600

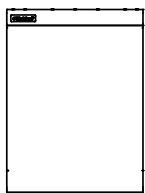

SPECIFICATIONS

Dimensions

Width 600mm
 Depth 805mm
 Height 915mm
 Incl. low back 970mm
 Incl. splashback option 1130mm

Nett weight

Cabinet Base models 59kg
 Leg Stand models 47kg

Packing data

Cabinet Base models
 0.55m³, 111kg
 Width 495mm
 Depth 870mm
 Height 1260mm
 Leg Stand models
 0.29m³, 83kg
 Width 495mm
 Depth 870mm
 Height 665mm

OPTIONS AT EXTRA COST

Castors
 Plinth mounting

MOFFAT

moffat.com.au
 moffat.co.nz

Australia
 moffat.com.au

Moffat Pty Limited

Victoria/Tasmania
 740 Springvale Road
 Mulgrave, Victoria 3170
 Telephone +613-9518 3888
 Facsimile +613-9518 3833
 vsales@moffat.com.au

New South Wales
 Telephone +612-8833 4111
 nswsales@moffat.com.au

South Australia
 Telephone +613-9518 3888
 vsales@moffat.com.au

Queensland
 Telephone +617-3630 8600
 qldsales@moffat.com.au

Western Australia
 Telephone 618-9413 2400
 wasales@moffat.com.au

New Zealand
 moffat.co.nz

Moffat Limited

Rolleston
 45 Illinois Drive
 Izone Business Hub
 Rolleston 7675
 Telephone +64 3-983 6600
 Facsimile +64 3-983 6660
 sales@moffat.co.nz

Auckland
 Telephone +64 9-574 3150
 sales@moffat.co.nz



ISO9001
 Quality
 Management
 Standard

Designed and manufactured by



ISO9001

All Waldorf Bold products are designed and manufactured by Moffat using the internationally recognised ISO9001 quality management system, covering design, manufacture and final inspection, ensuring consistent high quality at all times.

In line with policy to continually develop and improve its products, Moffat Limited reserves the right to change specifications and design without notice.

© Copyright Moffat Ltd
 AN.WBD.S.02.19

an Ali Group Company



The Spirit of Excellence