

## Bench Top Corner Unit 550mm

BTLB8550-CD-LH, BTLB8550-CD-RH



BTLB550-CD-LH

### OVERALL CONSTRUCTION

#### WORK BENCH

- 3.5mm thick compound work surface
  - 1.5mm 304 stainless steel top
  - 2.0mm galvanised steel backing
- Welded 1.5mm stainless steel bull nose
- Splashback and side panels 1.2mm stainless steel

#### CABINET BASE (SUPPLIED AS –CD MODEL)

- Modular for suite matched finish
- Double skin 0.9mm stainless steel interior and exterior
- GN 1/1 4 position racking kit
- 63mm dia. heavy-duty 1.2mm stainless steel legs with adjustable feet

- Heavy-duty construction
- Cabinet Base
- Stainless steel exterior
- Black vitreous enamel finish to front panels
- Easy clean
- Fully modular

### Series Options

BTLB - Low back models

BTB - 215mm splashback option

---

# Waldorf Bold

## Bench Top Corner Unit 550mm

BTLB8550-CD-LH

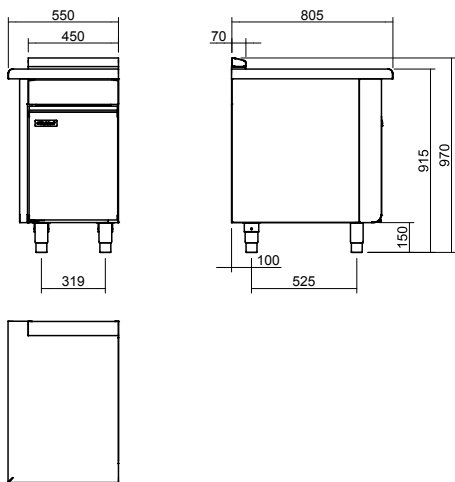

BTLB8550-CD-RH

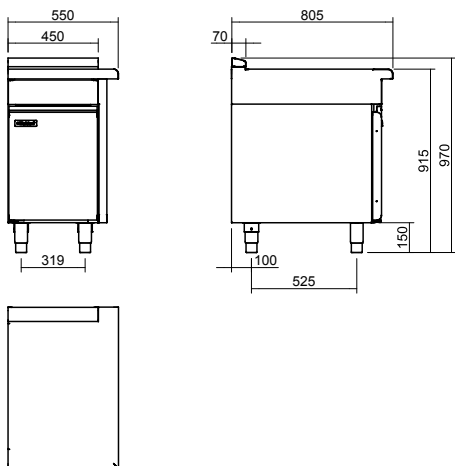

### SPECIFICATIONS

#### Dimensions

Width 550mm

Depth 805mm

Height 915mm

Incl. low back 970mm

Incl. splashback option 1130mm

#### Nett weight

47kg

#### Packing data

0.704m<sup>3</sup>, 99kg

Width 645mm

Depth 860mm

Height 1260mm

#### OPTIONS AT EXTRA COST

Castors

Plinth mounting

**MOFFAT**

moffat.com.au

moffat.co.nz

#### Australia

moffat.com.au

#### Moffat Pty Limited

Victoria/Tasmania  
740 Springvale Road  
Mulgrave, Victoria 3170  
Telephone +613-9518 3888  
Facsimile +613-9518 3833  
vsales@moffat.com.au

New South Wales  
Telephone +612-8833 4111  
nswsales@moffat.com.au

South Australia  
Telephone +613-9518 3888  
vsales@moffat.com.au

Queensland  
Telephone +617-3630 8600  
qldsales@moffat.com.au

Western Australia  
Telephone 618-9413 2400  
wasales@moffat.com.au

#### New Zealand

moffat.co.nz

#### Moffat Limited

Rolleston  
45 Illinois Drive  
Izone Business Hub  
Rolleston 7675  
Telephone +64 3-983 6600  
Facsimile +64 3-983 6660  
sales@moffat.co.nz

Auckland  
Telephone +64 9-574 3150  
sales@moffat.co.nz



ISO9001  
Quality  
Management  
Standard

Designed and manufactured by



ISO9001

All Waldorf Bold products are designed and manufactured by Moffat using the internationally recognised ISO9001 quality management system, covering design, manufacture and final inspection, ensuring consistent high quality at all times.

In line with policy to continually develop and improve its products, Moffat Limited reserves the right to change specifications and design without notice.

© Copyright Moffat Ltd  
AN.WBD.S.02.19

an Ali Group Company



The Spirit of Excellence