

Technical data sheet for

TARGET TOP 900mm

RN8100G-B, RN8100G-CB, RN8100G-LS, RN8100G-RB



RN8100G-LS

- Heavy-duty cast iron top with removable centre ring
- Matched modular height machined top for seamless work surface
- High output dual ring cast iron burner
- 3 models of base unit
- 1 model of refrigerated base with two GN 1/1 drawers
- Stainless steel exterior
- Easy clean
- Easy service
- Fully modular
- Low back models (RNL) available

Overall Construction

TARGET TOP

- 3 piece heavy-duty cast iron top with fully machined surface
- Top plates and removable centre with integral spill protection design
- Cast top reinforced with integral heat fins for heat zone definition
- 45MJ dual ring cast iron burner with single control
- Full pilot and flame failure protection
- 50mm thick refractory brick lined burner box for high heat retention
- Welded hob surround with 1.5mm 304 stainless steel bull nose
- Splashback and side panels 1.2mm 304 stainless steel
- Front panels 0.9mm 304 stainless steel
- 2 vitreous enamelled spill trays
- Supplied with heavy-duty centre casting removal tool

BENCH MOUNT (SUPPLIED AS –B MODEL)

- Four 63mm dia. heavy-duty 1.2mm 304 stainless steel bench legs with adjustable feet.
- Adjustable height 80mm – 105mm

CABINET BASE (SUPPLIED AS –CB MODEL)

- Fully modular for match suite finish
- Double skin 0.9mm 304 stainless steel interior and exterior
- Optional GN 1/1 4 position racking kit (1 or 2 cabinet bays)
- Up to eight 65mm GN 1/1 capacity
- 63mm dia. heavy-duty 1.2mm 304 stainless steel legs with adjustable feet

LEG STAND (SUPPLIED AS –LS MODEL)

- Fully modular for matched suite finish
- Framed top for connection to Target Top
- 63mm dia. heavy-duty 1.2mm 304 stainless steel legs with adjustable feet
- Fully modular framed stand shelf with 0.9mm 304 stainless steel finish
- Suitable for rear or through shelf gas connection to Target Top
- Quick assembly design (no tools required)

REFRIGERATED BASE (SUPPLIED AS –RB MODEL)

- Self contained suite matched modular base
- Ventilated system with R134a refrigerant
- -2° to + 8°C temperature (Tropical Climate rated)
- Two GN 1/1 drawers
- 100mm deep pan capacity
- Heavy-duty European telescopic drawer guides
- Magnetic drawer gaskets (replaceable without tools)
- 50mm fully foamed CFC free insulation
- 304 stainless steel exterior and interior
- Anti-corrosion treated evaporator
- No condensate drain required
- 63mm dia. heavy-duty 1.2mm 304 stainless steel legs with adjustable feet
- Condensing unit removable through front of unit for service
- Easy clean interior

Controls

TARGET TOP

- Large easy use control knob - heat resistant reinforced
- Easy view control settings on knob
- Variable high to low burner control
- Single control knob for burner and pilot system
- Flame failure pilot burner
- Manual pilot ignition for reliable operation

REFRIGERATED BASE

- Digital control electronic thermostat
- Automatic defrost
- Automatic evaporation of defrost water
- -2 to +8°C temperature range

Cleaning and Servicing

- All models with easy clean stainless steel external finish
- Target Top fully serviceable from front of unit
- Refrigerated Base condenser removable through front of unit

Technical data sheet for TARGET TOP 900mm



Specifications

TARGET TOP

Burner

Dual ring cast iron burner

Gas power

45MJ/hr, 12.5kw

Top plate

Cooking surface 900mm x 625mm, 5625cm²

Centre 280mm diameter

Maximum plate temperature at centre 500° C

Gas connection

R 3/4 (BSP) male

130mm from RH side, 32mm from rear,

and 655mm from floor

All units supplied with Natural and LP gas regulator

REFRIGERATED BASE

Type

Ventilated system

Refrigerant

R134a (160grams)

Climate classification

T – tropical

Electrical connection

220-240Vac, 50Hz, 1.8A, 1P+N+E

3 pin 10A plug cordset fitted

DIMENSIONS

Bench models

Width 900mm

Depth 805mm

Height 315mm

Incl. splashback 530mm

Incl. low back 370mm

All models (excluding Bench model)

Width 900mm

Depth 805mm

Height 915mm

Incl. splashback 1130mm

Incl. low back 970mm

NETT WEIGHT

Bench and Leg Stand models

178kg

Cabinet Base and Refrigerated Base models

222kg

PACKING DATA

Bench and Leg Stand models

0.55m³, 223kg

Width 945mm

Depth 870mm

Height 665mm

Cabinet Base and Refrigerated Base models

1.03m³, 287kg

Width 945mm

Depth 870mm

Height 1255mm

GAS TYPES

Available in Natural gas and LP gas

Please specify when ordering

Units supplied complete with gas type

conversion kits

Other gas types on request

OPTIONS AT EXTRA COST

Joining caps

Castors

Plinth mounting

BENCH MODEL

RN8100G-B

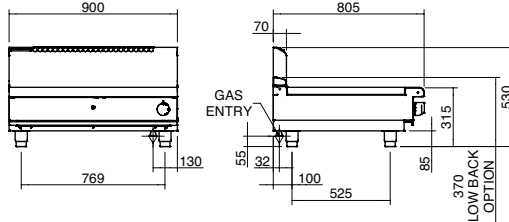

CABINET BASE

RN8100G-CB

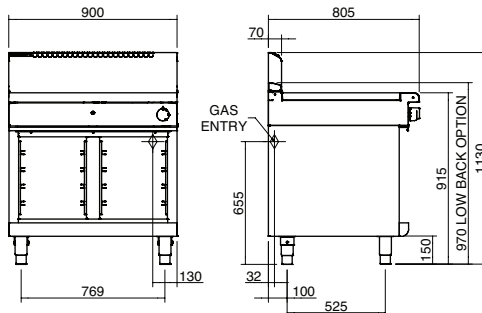

LEG STAND

RN8100G-LS

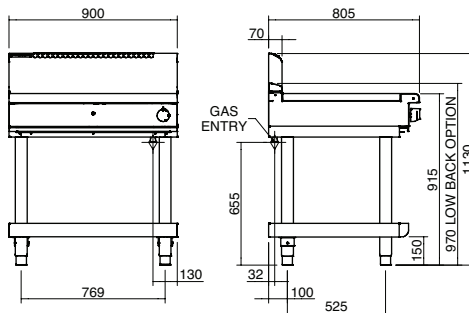

REFRIGERATED BASE

RN8100G-RB

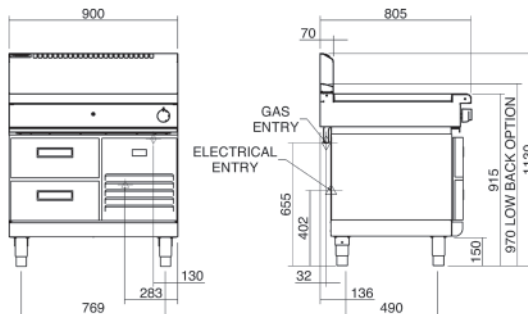

PLAN

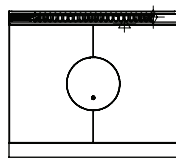

moffat.com.au

moffat.co.nz

Australia

moffat.com.au

Moffat Pty Limited

Victoria/Tasmania

740 Springvale Road

Mulgrave, Victoria 3170

Telephone +613-9518 3888

Facsimile +613-9518 3833

vsales@moffat.com.au

New South Wales

Telephone +612-8833 4111

nswsales@moffat.com.au

South Australia

Telephone +613-9518 3888

vsales@moffat.com.au

Queensland

Telephone +617-3630 8600

qldsales@moffat.com.au

Western Australia

Telephone +618-9413 2400

wasales@moffat.com.au

New Zealand

moffat.co.nz

Moffat Limited

Rolleston

45 Illinois Drive

Izone Business Hub

Rolleston 7675

Telephone +64 3-983 6600

Facsimile +64 3-983 6660

sales@moffat.co.nz

Auckland

Telephone +64 9-574 3150

sales@moffat.co.nz



ISO9001
Quality
Management
Standard



Cert. No. 6872

In line with policy to continually develop and improve its products, Moffat Limited reserves the right to change specifications and design without notice.

© Copyright Moffat Ltd
AN.W8.01.2020

an Ali Group Company



The Spirit of Excellence