

Technical data sheet for

## BENCH TOPS 600mm

BT8600-CB, BT8600-LS

---



BT8600-CB

- Heavy-duty construction
- Cabinet Base or Leg Stand
- Stainless steel exterior
- Easy clean
- Fully modular

### Series Options

- BT** - Standard splashback models
- BTL** - Low back models
- BTB** - Bold vitreous enamel colour front finish on standard splashback models
- BTLB** - Bold vitreous enamel colour front finish on low back models

### Overall Construction

#### WORK BENCH

- 3.5mm thick compound work surface
  - 1.5mm 304 stainless steel top
  - 2.0mm galvanised steel backing
- Welded 1.5mm stainless steel bull nose
- Splashback and side panels 1.2mm stainless steel

#### CABINET BASE (SUPPLIED AS –CB MODEL)

- Modular for suite matched finish
- Double skin 0.9mm stainless steel interior and exterior
- GN 1/1 4 position racking kit
- 63mm dia. heavy-duty 1.2mm stainless steel legs with adjustable feet

#### LEG STAND (SUPPLIED AS –LS MODEL)

- Modular for suite matched finish
  - 63mm dia. heavy-duty 1.2mm stainless steel legs with adjustable feet
  - Framed stand shelf with 0.9mm stainless steel finish
  - Quick assembly design (no tools required)
-

# Technical data sheet for BENCH TOPS 600mm

## Specifications

### DIMENSIONS

**All models**  
Width 600mm  
Depth 805mm  
Height 915mm  
Incl. splashback 1130mm  
Incl. low back 972mm

### NETT WEIGHT

**Cabinet Base models**  
59kg

**Leg Stand models**  
47kg

### PACKING DATA

**Cabinet Base models**  
0.55m<sup>3</sup>, 111kg  
Width 495mm  
Depth 870mm  
Height 1260mm

**Leg Stand models**  
0.29m<sup>3</sup>, 83kg  
Width 495mm  
Depth 870mm  
Height 665mm

### OPTIONS AT EXTRA COST

Castors  
Plinth mounting

**BT8600-CB, BTL8600-CB**

**CABINET BASE**

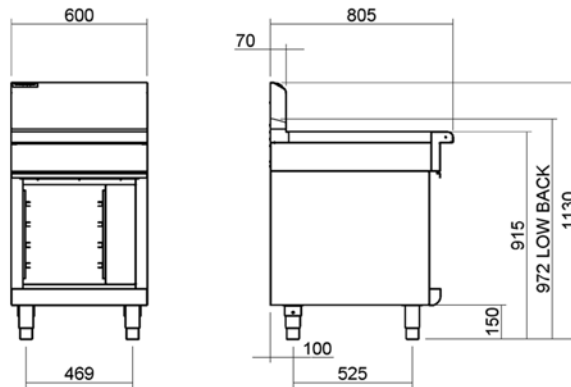

**BT8600-LS, BTL8600-LS**

**LEG STAND**

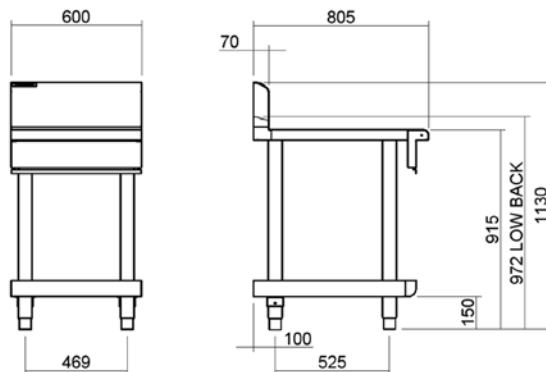

**BT8600**

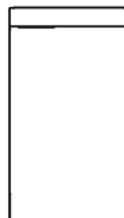

[moffat.com.au](http://moffat.com.au)  
[moffat.co.nz](http://moffat.co.nz)

**Australia**  
[moffat.com.au](http://moffat.com.au)

### Moffat Pty Limited

Victoria/Tasmania  
740 Springvale Road  
Mulgrave, Victoria 3170  
Telephone +613-9518 3888  
Facsimile +613-9518 3833  
[vsales@moffat.com.au](mailto:vsales@moffat.com.au)

New South Wales  
Telephone +612-8833 4111  
[nswsales@moffat.com.au](mailto:nswsales@moffat.com.au)

South Australia  
Telephone +613-9518 3888  
[vsales@moffat.com.au](mailto:vsales@moffat.com.au)

Queensland  
Telephone +617-3630 8600  
[qldsales@moffat.com.au](mailto:qldsales@moffat.com.au)

Western Australia  
Telephone +618-9413 2400  
[wasaes@moffat.com.au](mailto:wasaes@moffat.com.au)

**New Zealand**  
[moffat.co.nz](http://moffat.co.nz)

### Moffat Limited

Rolleston  
45 Illinois Drive  
Izone Business Hub  
Rolleston 7675  
Telephone +64 3-983 6600  
Facsimile +64 3-983 6660  
[sales@moffat.co.nz](mailto:sales@moffat.co.nz)

Auckland  
Telephone +64 9-574 3150  
[sales@moffat.co.nz](mailto:sales@moffat.co.nz)



In line with policy to continually develop and improve its products, Moffat Limited reserves the right to change specifications and design without notice.

© Copyright Moffat Ltd  
AN.W8.08/19