

Technical data sheet for

GAS TILTING BRATT PAN 900mm

BP8080G, BP8080GE



BP8080G

- 80L full stainless steel pan
- Manually operated tilting mechanism
- Optional electric power tilting mechanism
- Heavy-duty lid and hinge system
- Galvanized steel chassis
- Stainless steel exterior
- Easy clean
- Easy service
- Fully modular
- Low back models (BPL) available

Overall Construction

- Heavy-duty galvanized steel chassis
- Splashback and side panels 1.2mm 304 stainless steel
- Front panels 0.9mm 304 stainless steel
- Full stainless steel pan with 2.0mm pan body
- 12mm thick stainless steel even heat pan base
- Large capacity pouring spout
- Heavy-duty spring balanced lid hinge system
- 1.5mm 304 stainless steel lid suitable as bench-top workspace
- Full width stainless steel lid handle
- Manually operated pan lift handwheel with fold-away handle
- Electrically powered pan tilting option
- 63mm dia. heavy-duty stainless steel legs with adjustable feet

Controls

- Large easy use control knobs - heat resistant reinforced
- Easy view control settings on knobs
- Single control for power and heating control
- Indicator lights for power and heating
- Quarter turn water valve control for ease of use
- Automatic pilot ignition and flame failure fitted
- 50-320°C electric thermostatic burner control
- Over temperature safety cut-out
- Fold away handle on manual pan tilt
- Pan up and down switches on electric pan tilt

Cleaning and Servicing

- Seamless full stainless steel pan with rounded corners
 - Easy clean stainless steel exterior panels
 - Easy connection access via front service panels
 - Service friendly lid hinge system
 - Access to all parts from front of unit
-

Technical data sheet for

GAS TILTING BRATT PAN 900mm

BP8080G, BP8080GE

Specifications

Burner

Single 6 bar stainless steel burner 75MJ/hr

Gas power

75MJ/hr, 21kW

Pan

Cooking surface 780mm x 450mm, 3510cm²

215mm deep

Gas connection

R 3/4 (BSP) male, 60mm from LH side,

305mm from rear, and 122mm from floor

All units supplied with Natural and LP gas regulator

Water connection

Cold water connection 270mm from side,

574mm from rear, and 252mm from floor

1/2" tube connection via 15mm crox fitting

550kpa, 80psi max water pressure

Electrical connection

220-240Vac, 50/60Hz, 1A, 1P+N+E

3 pin 10A plug cordset fitted

DIMENSIONS

Width 900mm

Depth 805mm

Height 915mm

Incl. splashback 1130mm

Incl. low back 970mm

With lid open 1600mm

NETT WEIGHT

170kg

PACKING DATA

1.03m³, 236kg

Width 945mm

Depth 870mm

Height 1255mm

GAS TYPES

Available in Natural gas and LP gas

Please specify when ordering

Units supplied complete with gas type conversion kits

Other gas types on request

OPTIONS AT EXTRA COST

Joining caps

Plinth mounting

BP8080G

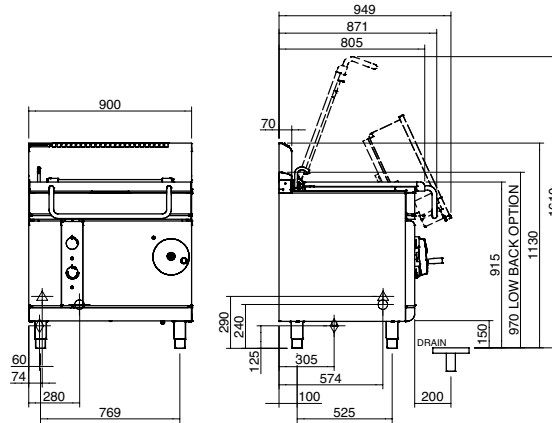

BP8080GE

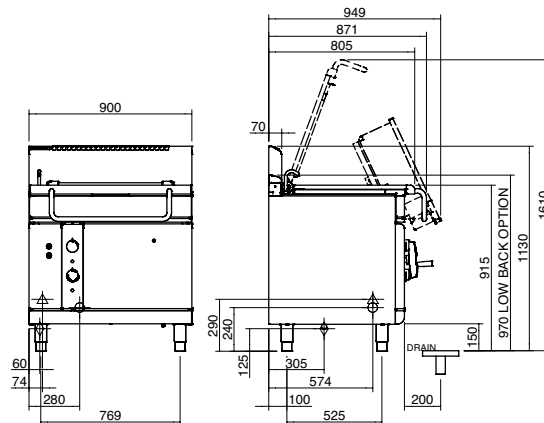

PLAN

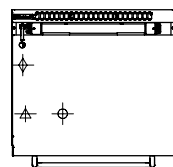

△ = ELECTRICAL CONNECTION POINT.

◇ = GAS CONNECTION POINT.

⊕ = WATER CONNECTION POINT.



moffat.com.au
moffat.co.nz

Australia
moffat.com.au

Moffat Pty Limited

Victoria/Tasmania
740 Springvale Road
Mulgrave, Victoria 3170
Telephone +613-9518 3888
Facsimile +613-9518 3833
vsales@moffat.com.au

New South Wales
Telephone +612-8833 4111
nswsales@moffat.com.au

South Australia
Telephone +613-9518 3888
vsales@moffat.com.au

Queensland
Telephone +617-3630 8600
qldsales@moffat.com.au

Western Australia
Telephone +618-9413 2400
wasales@moffat.com.au

New Zealand
moffat.co.nz

Moffat Limited

Rolleston
45 Illinois Drive
Izone Business Hub
Rolleston 7675
Telephone +64 3-983 6600
Facsimile +64 3-983 6660
sales@moffat.co.nz

Auckland
Telephone +64 9-574 3150
sales@moffat.co.nz



Cert. No. 6923

In line with policy to continually develop and improve its products, Moffat Limited reserves the right to change specifications and design without notice.

© Copyright Moffat Ltd
AN.W8.08/19