

Convotherm maxx pro easyDial Combi Steamer

CXEBD6.10 ELECTRIC BOILER 7 x 1/1 GN

- Boiler system
- Natural Smart Climate™ (ACS+) cooking methods: Steam, Combi-steam, Convection
- Natural Smart Climate™ extra functions:
 - Crisp&Tasty - 5 moisture removal settings
 - BakePro - 5 levels of traditional baking
 - HumidityPro - 5 humidity settings
 - Controllable fan - 5 speed settings
- easyDial: all functions are set on one operating level
- ConvoClean fully automatic cleaning system
- HygieniCare
- USB port integrated in the control panel
- TriColor indicator ring - indicates the current operating status
- Steam generated by high-performance boiler outside the cooking chamber
- LED lighting in oven cavity
- Triple glass appliance door
- Right-hinged appliance door



Standard Features

- Cooking methods:
 - Steam (30-130°C) with guaranteed steam saturation
 - Combi-steam (30-250 °C) with automatic moisture control
 - Convection (30-250 °C) with optimised heat transfer
- Operation of easyDial user interface:
 - Central control unit, Convotherm-Dial (C-Dial)
 - Digital display
- Climate Management
 - Natural Smart Climate™ (ACS+), HumidityPro, Crisp&Tasty
- Quality Management
 - Airflow Management, BakePro, Multi-point core temperature probe
- Production Management
 - 99 cooking profiles each containing up to 9 steps
 - HACCP data storage
 - USB port
 - Regenerating function - regenerates products to their peak level
 - Preheat and cool down function
- Cleaning Management:
 - ConvoClean: Fully automatic cleaning system, with optional single-dose dispensing
- HygieniCare: safety by antibacterial surfaces
 - Hygienic Handles
- Door handle with safety latch and sure-shut function

- Adjustable appliance feet, from 100 mm to 125 mm
- Integrated recoil hand shower

Options

- Steam and vapour removal (built-in condensation hood)
- Sous-vide sensor, with external socket
- Core temperature sensor, with external socket
- Ethernet / LAN interface
- Marine model
- Available in various voltages

Accessories

- Stainless steel stand
- Stacking kit
- ConvoLink – HACCP and cooking profile management PC software
- ConvoVent 4 condensation hood with grease filter
- ConvoVent 4+ condensation hood with grease and odour filter
- Banquet system package: plate rack, mobile shelf rack, transport trolley, thermal cover (individual items are available)
- Care products for ConvoClean fully automatic cleaning system (multiple and single-dose dispensing)

Convotherm maxx pro easyDial Combi Steamer

CXEBD6.10 ELECTRIC BOILER 7 x 1/1 GN

Front view

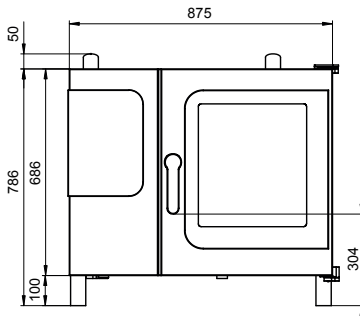

View from above with wall clearances

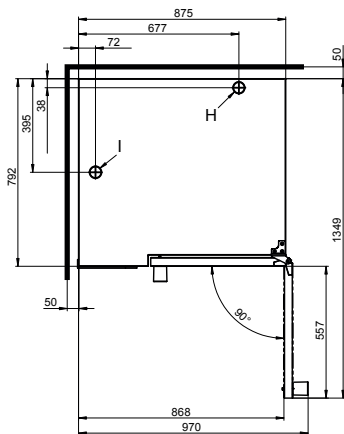

Connection points

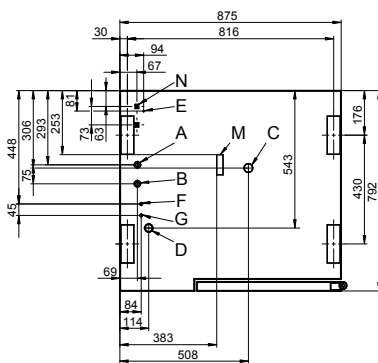

- A Water connection (for boiler)
- B Water connection (for cleaning, recoil hand shower)
- C Drain connection DN 50
- D Electrical connection
- E Equipotential bonding
- F Rinse-aid connection
- G Cleaning-agent connection
- H Air vent Ø 50 mm
- I Dry air intake Ø 50 mm
- M Safety overflow 80 x 25 mm
- N RJ45 Ethernet port

DIMENSIONS

Width	875 mm
Depth	792 mm
Height	786 mm
Weight	133kg

PACKED DIMENSIONS

Width	1100 mm
Depth	940 mm
Height	1025 mm
Weight (including cleaning system)	158 kg

Safety clearances*

Rear	50 mm
Right	50 mm
Left (larger recommended for servicing)	50 mm
Top (for ventilation)	500 mm

*Heat sources must lie at a minimum distance of 500 mm from the appliance.

INSTALLATION REQUIREMENTS

For precise installation instructions please refer to the units installation manual

LOADING CAPACITY

Max. number of food containers	
Shelf distance	68mm
GN 1/1 (with standard rack)	7
600 x 400 baking sheet (with appropriate rack)	5
Max. loading weight GN 1/1 / 600 x 400	
Per combi steamer	30 kg
Per shelf	15 kg

ELECTRICAL SUPPLY

3N - 400V 50/60Hz (3P+N+E)	
Rated power consumption	11.0 kW
Rated current	15.9 A
Fuse	16 A
RCD (GFCI), frequency converter	Type A
(singlephase)	(recommended), type B (optional)

Special voltage options available on request.
Connection to an energy optimisation system as standard.

WATER CONNECTION

Water supply	
2 x G 3/4" permanent connection, optionally including connecting pipe (min. DN13 / 1/2")	
Flow pressure	150 - 600 kPa (1.5 - 6 bar)
Appliance drain	
Drain version	Permanent connection (recommended) or funnel waste trap
Type	DN50 (min. internal Ø: 46 mm)
Slope for waste-water pipe	min. 3.5% (2°)

WATER QUALITY

Drinking water	
Total hardness	
Cleaning, recoil shower	4-20 °dh / 70 - 360 ppm /
Shower, boiler	7 - 35°TH / 5 - 25°e
Properties	
pH	6.5 - 8.5
Cl ⁻ (chloride)	max. 60 mg/l
Cl ₂ (free chlorine)	max. 0.2 mg/l
SO ₄ ²⁻ (sulphate)	max. 150 mg/l
Fe (iron)	max. 0.1 mg/l
Temperature	max. 40°C
Electrical conductivity	min. 20 µS/cm

EMISSIONS

Heat output	
Latent heat	2100 kJ/h / 0.58 kW
Sensible heat	2500 kJ/h / 0.69 kW
Waste water temperature	max. 80 °C
Noise during operation	max. 70 dBA

STACKING KIT

Permitted combinations	6.10 on 6.10 / 6.10 on 10.10
(Electric on electric appliance)	



moffat.com.au
moffat.co.nz

Australia
moffat.com.au

Moffat Pty Limited

Victoria/Tasmania
740 Springvale Road
Mulgrave, Victoria 3170
Telephone +61 3-9518 3888
Facsimile +61 3-9518 3833
vsales@moffat.com.au

New South Wales
Telephone +61 2-8833 4111
nswsales@moffat.com.au

South Australia
Telephone +61 3-9518 3888
vsales@moffat.com.au

Queensland /
Northern Territory
Telephone +61 7-3630 8600
qldsales@moffat.com.au

Western Australia
Telephone +61 8-9413 2400
wasales@moffat.com.au

New Zealand
moffat.co.nz

Moffat Limited

Rolleston
45 Illinois Drive
Izone Business Hub
Rolleston 7675
Telephone +64 3-983 6600
Facsimile +64 3-983 6660
sales@moffat.co.nz

Auckland
Telephone +64 9-574 3150
sales@moffat.co.nz

In line with policy to continually develop and improve its products, Moffat Limited reserves the right to change specifications and design without notice.

© Copyright Moffat Ltd
AN.CON.S.2101

