

Convotherm mini easyTouch Combi Steamer

CMINIT6.06 / CMINT6.06B ELECTRIC DIRECT STEAM 6 X 2/3 GN

- Direct steam system
- Requires minimum space - fits anywhere, saving expensive floor space
- Natural Smart Climate™ (ACS+) cooking methods: Steam, Combi-steam, Convection
- Natural Smart Climate™ extra functions:
 - Crisp&Tasty - 3 moisture removal settings
 - HumidifyPro - 3 humidity settings
 - BakePro - 3 levels of traditional baking
 - Reduced fan speed and auto-reverse mode
- easyTouch 7" TFT HiRes glass touch display (capacitive)
- ConvoClean+ fully automatic cleaning system with 3 intensity levels and express mode
- HygieniCare
- WiFi and Ethernet interface (LAN)
- USB port integrated in the control panel
- Hand shower
- Right-hinged appliance door



Standard Features

- Cooking methods:
 - Steam (30-130°C) with guaranteed steam saturation
 - Combi-steam (30-250 °C) with automatic moisture control
 - Convection (30-250 °C) with optimised heat transfer
 - Regenerating function
- Operation of easyTouch user interface:
 - 7" TFT HiRes glass touch display (capacitive)
 - Smooth-action, quick reacting scrolling function
- Climate Management
 - Natural Smart Climate™ (ACS+), HumidityPro, Crisp&Tasty
- Quality Management
 - Airflow Management, BakePro, Multi-point core temperature probe
 - Preheat and cool down function
- Production Management
 - Automatic cooking with Press&Go with up to 399 cooking profiles
 - Integrated cookbook with 6 different categories
 - TrayTimer – load management for different products at the same time (manual mode)
 - TrayView – load management for automatic cooking of different products using Press&Go
 - Favourites management
 - HACCP data storage
 - USB port
 - ecoCooking – energy-save function
 - LT cooking (low temperature cooking) / Delta-T cooking
 - Cook&Hold – cook and hold in one process
 - Autostart
 - Regenerate - flexible multi-mode rethermalisation function with preselect

- Cleaning Management:
 - ConvoClean+ - fully automatic cleaning system with 3 intensity levels, with a Clean and Care booster function
 - 10 minute express cleaning
 - 2 minute QuickRinse (rinse with water)
 - Safe Cool Down function before cleaning (when door is closed)
 - Cleaning profiles can be set individually as favourites
 - Cleaning scheduler
 - Hand shower with infinitely variable flow adjust
- HygieniCare: safety by antibacterial surfaces
 - Hygienic handles (door and hand-shower handles)
 - Hygienic Steam function
 - Hygienic touch film

Options

- Left-hinged appliance door
- Available in various voltages
- Safety door latch (with sure-shut function and venting position)

Accessories

- Stands in various sizes and designs
- Care products for ConvoClean cleaning system
- Wall holder
- mini condensation hood & Pro hood
- RO Systems available if water quality is outside of specification

Convotherm mini easyTouch Combi Steamer

CMINIT6.06 / CMINT6.06B ELECTRIC DIRECT STEAM 6 X 2/3 GN

Front view

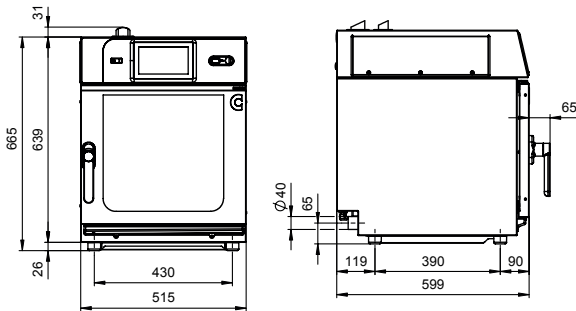

View from above with wall clearances

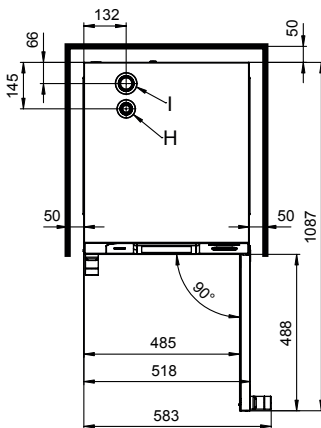

Rear view

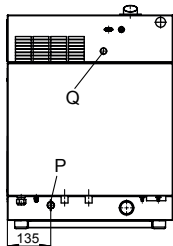

Connection positions in appliance floor

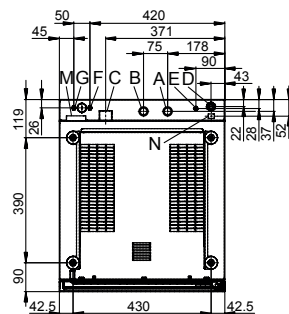

- | | |
|--|--|
| A Water supply connection (for water injection) | G Cleaning agent connection |
| B Water supply injection (for cleaning) | H Air vent \varnothing 30 mm |
| C Drain connection DN 40 | I Dry air intake \varnothing 43 mm |
| D Electrical connection | M Safety overflow 60 mm x 20 mm |
| E Equipotential bonding | N RJ45 Ethernet port |
| F Rinse aid connection | P mini Condensation Hood Pro - optional |
| | Q Safety thermostat reset |

DIMENSIONS

Width	515 mm
Depth	599 mm
Height	665 mm
Weight	45 kg

PACKED DIMENSIONS

Width	580 mm
Depth	740 mm
Height	850 mm
Weight (including cleaning system)	58 kg

Safety clearances

Rear	50 mm
Right	50 mm
Left	50 mm
(larger recommended for servicing)	
Top (for ventilation)	500 mm

INSTALLATION REQUIREMENTS

Appliance must be installed level. Do not install the appliance near, above or below a source of heat or near flammable surfaces

LOADING CAPACITY

Shelf distance	40mm
GN 2/3 shelves (40mm deep)	6

ELECTRICAL SUPPLY

1N~230-240V ~50/60Hz (1P+N+E) or	
3N~400-415V ~50/60Hz (3P+N+E)	
Connected load	5,7 kW
Rated current	11,8 A
Fit main switch (all-pin-circuit-breaker) on site, in close proximity to the appliance. Connection for potential compensation.	

WATER CONNECTION

Water supply
Cold water R3/4" 2 - 6 bar flow pressure. Fit water tap and dirt filter on site in close proximity to appliance
Backflow prevention valve (supplied)

WATER QUALITY

Drinking water	
Overall hardness	70-125 ppl
Properties	
pH	6,5 - 8,5
Cl ⁻ (chloride)	max. 60 mg/l
Cl ₂ (free chlorine)	max. 0,2 mg/l
SO ₄ ²⁻ (sulphate)	max. 150 mg/l
Fe (iron)	max. 0,1 mg/l
Electrical conductivity	min 20 μ S/cm

Water outlet

R40, fixed connection or funnel siphon

EMISSIONS

Heat output	
Latent heat	1000 KJ/h
Sensible heat	1100 KJ/h
Noise during operation	max. 70 dBA
Spray guard	1Px4



Australia
moffat.com.au

New Zealand
moffat.co.nz

Australia
Moffat Pty Limited

Victoria/Tasmania
740 Springvale Road
Mulgrave, Victoria 3170
Ph 03-9518 3888
Fax 03-9518 3833
vsales@moffat.com.au
www.moffat.com.au

New South Wales
Ph 02-8833 4111
nswsales@moffat.com.au

South Australia
Ph 03-9518 3888
vsales@moffat.com.au

Queensland
Ph 07-3630 8600
qldsales@moffat.com.au

Western Australia
Ph 08-9413 2400
wasales@moffat.com.au

New Zealand
Moffat Limited

Christchurch
45 Illinois Drive
Izone Business Hub
Rolleston 7675
New Zealand
Telephone +64 3-983 6600
Facsimile +64 3-983 6660
sales@moffat.co.nz

Auckland
Ph +64 9-574 3150
sales@moffat.co.nz

In line with policy to continually develop and improve its products, Moffat Limited reserves the right to change specifications and design without notice.

© Copyright Moffat Ltd
AN.CON.S.1.22

