

CSP6

600mm Gas Waterless Stockpot



CSP6

- 800mm compact depth
- Low 600mm potstand height
- Cobra suite matching
- 70 MJ/hr 18 jet Duckbill burner¹
- High splashback with shelf
- Pot filling water laundry swivel arm on splashback
- Stainless steel deck
- Rear waste channel
- Stainless steel spill tray
- Cast iron potstand
- Suits up to 150L Stockpot
- Flame failure protection with pilot burner

OVERALL CONSTRUCTION

- Full chassis construction
- Double skin insulated deck
- Stainless steel exterior finish
- Heavy-duty cast iron pot stand
- Stainless steel spill tray
- 63mm dia. stainless steel legs with adjustable feet

CONTROLS

- Pilot On/Off control with flame failure valve
- Main burner On/Off valve with High-Low burner adjustment
- Quarter turn main burner control handles
- Quarter turn water valve handle

CLEANING AND SERVICING

- Stainless steel exterior finish
- Lift off potstand for full cleaning ability
- Slide out spill tray
- Rear waste channel with removable grate for debris collection
- Access to all parts from front and top for servicing



Duckbill burner

¹ NZ models Duckbill burner rating 105MJ/hr Natural Gas / 85MJ/hr on LP gas.

Matching Products



CW2H

CN4

CT9

CW3H

CW1H

CP4

CS9 / C900-S

C6B

CSP6

600mm Gas Waterless Stockpot

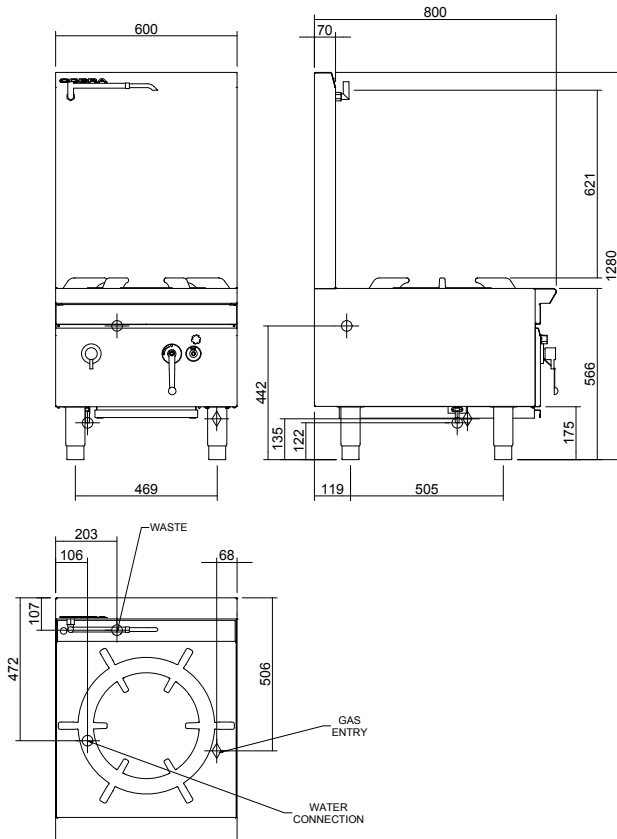

CSP6

SPECIFICATIONS

Burners
70MJ/hr 18 jet Duckbill burner

Gas Rating - Total
70MJ/hr

Cooking area
Stock Pot area 600mm x 600mm
Suits up to 150L stock pot

Gas connection
R3/4 (BSP) male
68mm from RH side, 506mm from rear, 135mm from floor

All units supplied with Natural-LP gas regulator
Supplied gas regulator includes Test Point for appliance operating pressure
Supplied regulator must be fitted to appliance gas connection when installed

Water connection
Cold water connection
1/2" O.D. copper tube
106mm from LH side, 472mm from rear, 122mm from floor

Drain connection
Connection to waste drain
1-1/4" BSP male diameter drain waste 203mm from LH side, 107mm from rear, 442mm from floor

Dimensions
Width 600mm
Depth 800mm
Height 566mm
Incl. splashback 1280mm

Nett weight
68kg

Packing data
0.76m³, 118kg
Width 635mm
Depth 865mm
Height 1382mm

Gas types
Available in Natural gas and LP gas, please specify when ordering



Cert. No. AGA 4337G

moffat.com.au
moffat.co.nz

Australia
moffat.com.au

Moffat Pty Limited

Victoria/Tasmania
740 Springvale Road
Mulgrave, Victoria 3170
Telephone +613-9518 3888
Facsimile +613-9518 3833
vsales@moffat.com.au

New South Wales
Telephone +612-8833 4111
nswsales@moffat.com.au

South Australia
Telephone +613-9518 3888
vsales@moffat.com.au

Queensland
Telephone +617-3630 8600
qldsals@moffat.com.au

Western Australia
Telephone +618-9413 2400
wasales@moffat.com.au

New Zealand
moffat.co.nz

Moffat Limited

Rolleston
45 Illinois Drive
Izone Business Hub
Rolleston 7675
Telephone +64 3-983 6600
Facsimile +64 3-983 6660
sales@moffat.co.nz

Auckland
Telephone +64 9-574 3150
sales@moffat.co.nz



ISO9001
Quality
Management
Standard

Designed and manufactured by



ISO9001
All Cobra products are designed and manufactured by Moffat using the internationally recognised ISO9001 quality management system, covering design, manufacture and final inspection, ensuring consistent high quality at all times.

In line with policy to continually develop and improve its products, Moffat Limited reserves the right to change specifications and design without notice.

© Copyright Moffat Ltd
AN.C.01.19 / 1598

an Ali Group Company



The Spirit of Excellence