

The Quietest Commercial Blender Available

The ultimate blender with unparalleled sound reduction, exceptional beverage blends, and improved speed of service.

Smart Product Design

- Up to 4 times quieter than the competition due to the advance vibration dampening technology; resulting in quality drinks in a more enjoyable atmosphere
- Magnetically secured floating sound enclosure is dramatically easier to clean and disassemble with no screws to damage the enclosure
- 6 program buttons with 34 optimized programs for easier, consistent blending
- Advance® container creates faster, smoother pouring and has a longer blade life resulting in time and cost savings along with improved customer experience
- Air management and powerful ≈3 peak output HP motor reduces noise, improves reliability, and reduces down time

STANDARD FEATURES:

- Advance Blade
- 1.4 litre high impact clear container
- 6 program buttons with 34 recipe programs to choose from
- 1-100 speed settings
- Pulse switch
- Automatic blend completion
- Sound reducing cover

PACK INCLUDES:

The Quiet One® with 1.4 litre high-impact, clear/stackable Advance® container complete with Advance blade assembly and lid, and removable compact enclosure.



Three year parts and one year labour warranty on motor and base. One year warranty on the container, lid, blade assembly, drive socket and sound enclosure against defects in material and workmanship.

DIMENSIONS	
On-Counter:	216W x 272D x 457H mm (Cover closed) 216W x 336D x 622H mm (Cover open)
TECHNICAL DATA	
Power Supply:	240V, 50Hz, 10A
Power Output:	1300W-1500W
Motor:	≈ 3.0HP
Weight:	9.0kg

SPECIFICATIONS ARE SUBJECT TO CHANGE WITHOUT NOTICE.

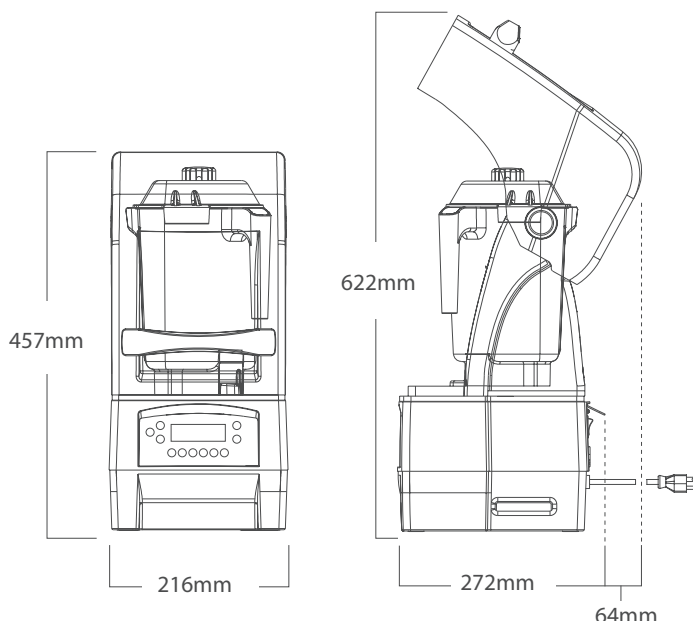

National Head Office
156 Swann Drive
Derrimut VIC 3026
Tel: +61 3 8369 4600
Fax: +61 3 8369 4699
www.comcater.com.au

Melbourne
96-100 Tope Street
South Melbourne VIC 3205
Tel: +61 3 8699 1200
Fax: +61 3 8699 1299

Sydney
20/4 Avenue of the Americas
Newington, NSW 2127
Tel: +61 2 8775 9500
Fax: +61 2 9648 4762

Brisbane
1/62 Borthwick Avenue
Murarrie QLD 4172
Tel: +61 7 3900 2700
Fax: +61 7 3399 5311

Perth
Unit 16, 7 Abrams Street
Balcatta, WA 6021
Tel: +61 8 6217 0700
Fax: +61 8 6217 0799