

The RMS510TSAA is a commercial microwave for light duty food service usage.

Light Duty Microwaves are an ideal replacement for inappropriate domestic ovens used in foodservice applications.

Tested to higher standards for a commercial rating — required by most commercial insurance policies and health inspectors.

20 programmable menu items simplifies cooking.

5 power levels and 4 cooking stages for cooking flexibility.

Multiple quantity pad calculates the proper cooking times for multiple portions.

IDEAL FOR:

- Convenience Stores
- Dessert stations
- Nurses stations
- Coffee shops
- Teachers/Staff lounge
- Vending



side view

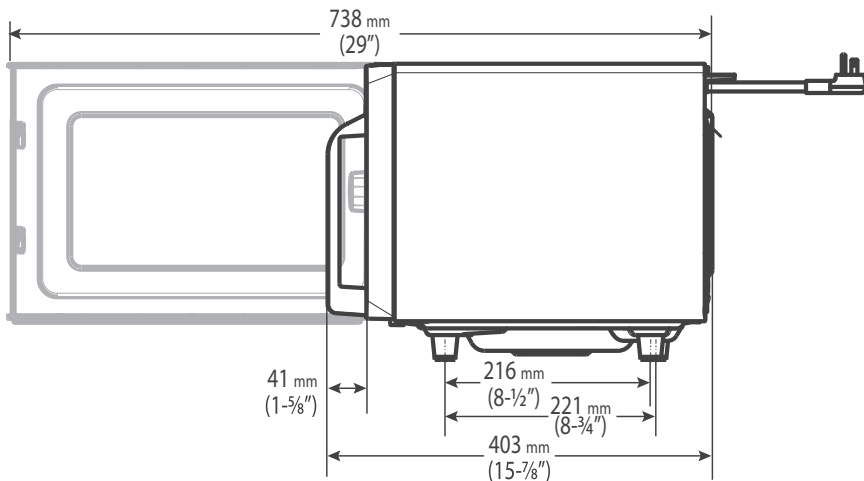

back view

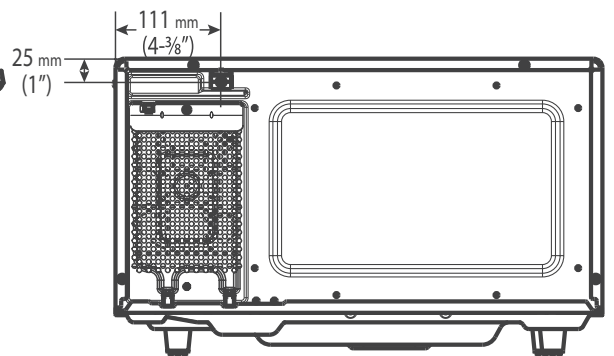

front view

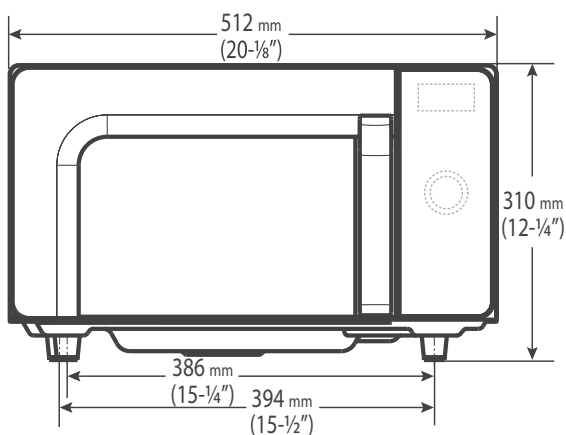

DIMENSIONS

External dimensions: 512W x 403D x 310H mm

Internal cavity: 330W x 330D x 197H mm

POWER SUPPLY

240V 50Hz 10A single phase

TECHNICAL DATA

Power output: 1000 watts

Internal cavity volume: 23 litres

External cabinet finish: Stainless steel

Internal cavity finish: Stainless steel

Memory programs: 20

Power levels: 5

Product weight: 13.6 kg

Shipping weight: 16.8kg

Magnetrons: 1

SPECIFICATIONS ARE SUBJECT TO CHANGE WITHOUT NOTICE.