

specifications

PG200HFr

SKOPE Pegasus Horizontal 2/1
REMOTE 1 Door Freezer (JK5301)

CABINET DIMENSIONS

	External	Internal
Height:	771mm*	565mm
Width:	1065mm	565mm
Depth:	828mm	650mm
Floor area:	0.88m ²	

* Height includes plinth and worktop (excludes castors and adjustable legs).

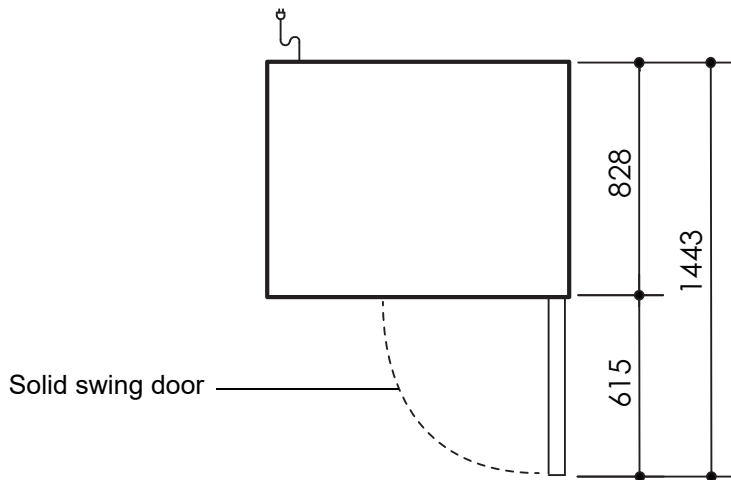

Dimensional tolerances			
Before installing this cabinet allow the following dimensional tolerances:			
Linear dimensions	Overall cabinet dimensions	Length of multiple cabinets	
		At each joint	At each end wall
Less than 1 metre	±5mm	±5mm	+15mm
More than 1 metre	-5mm to +10mm	-5mm to +10mm	+15mm

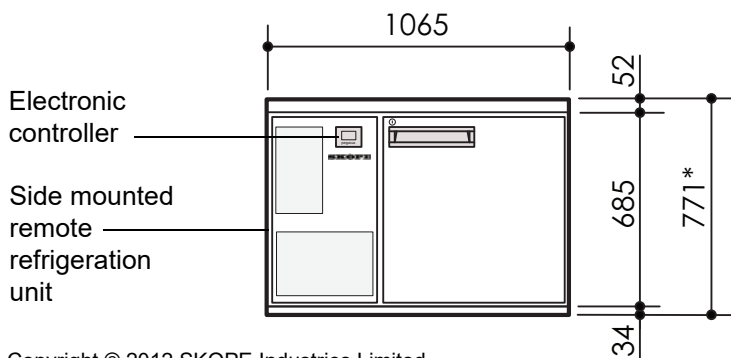

Pictured with optional 50mm stainless steel worktop

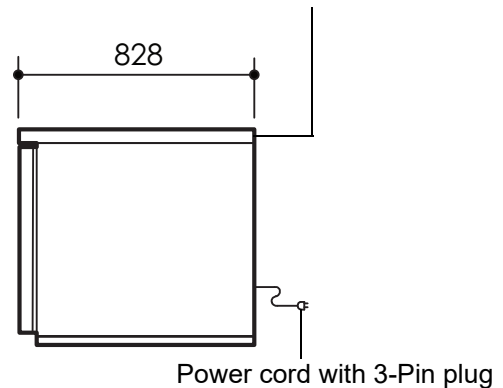

Copyright © 2012 SKOPE Industries Limited

CABINET SPECIFICATIONS

Refrigeration system:	Electronic controlled, side mounted, remote refrigeration unit
Refrigerant:	Thermostatic expansion valve fitted as standard to suit R404A/R452A
Pipe connection size:	Liquid line: 1/4". Suction line: 3/8"
Remote refrigeration duty:	180 Watts @ -30°C SST
Cabinet internal volume:	210 litres
Insulation:	60mm thick, high density cyclo-isopentane polyurethane foam
Cabinet temperature range:	-18°C to -21°C up to 43°C ambient
Drainage:	Evaporator drain fitted inside service compartment (requires plumbing)
Electrical:	230-240 Volts a.c. 50 Hz, 1.60 Amps
Internal lighting:	n.a.
Internal door opening size:	1 door opening: 565mm high x 565mm wide
Door:	Solid stainless steel, self-closing door (with key lock) - RH hinged
Worktop (optional):	Optional 50mm square edged stainless steel worktop
Shelves:	Two levels of non-tip, adjustable tray slides and/or shelves per door
Weight:	108 kg

SKOPE Industries Limited reserve the right to alter specifications without notice.

PSS0296 Rev 2.3 Nov. 2019



SKOPE INDUSTRIES LIMITED



New Zealand Freephone: 0800 947 5673, Fax: (03) 983 3896. Australian Freephone: 1800 121 535, Freefax: 1800 121 533

Email: enquiry@skope.co.nz Website: www.skope.co.nz