

## MF NEXT L



The propane blast chiller, ecological and completely customizable according to the needs of each professional choosing functions, type of performance, size of the display and the most useful features for its use.

### Yield

	Standard / Eco Silent	Turbo / Turbo Silent
Rapid blast chilling cycle capacity (90/+3°C)	70 kg	up to+30% kg/h
Rapid freezing cycle capacity (90/-18°C)	70 kg	up to+30% kg/h

Tests carried out in compliance with the Irinox procedure using 5-cm thick beef

### Capacity

Number of trays: 27 x GN1/1 o 600x400 (H= 20 mm)

Number of trays: 18 x GN1/1 o 600x400 (H= 40 mm)

Number of trays: 13 x GN1/1 o 600x400 (H= 65 mm)

### Standard construction details

- Door opening on the left with hinges on the left.
- Patented concealed hinges.
- Full height door with double bevelled side edges.
- Door opening up to 160°.
- Magnetic and slow closing of the door.
- Equipped with 10-chamber gasket designed for high and low temperatures.
- Core probe with 3 detection points with quick screw connector, anti-corrosion, watertight IP67.
- Large magnetic flat surface (400x150 mm) to fix the core probe.
- Easy removal and cleaning of the condenser filter thanks to the tilting grill.
- Ergonomic and robust handle made of steel.
- AISI 304 stainless steel internal and external material.
- Built-in air condensation.
- R290 refrigerant gas.
- MultiRack®, the patented adjustable tray holder that doubles the number of trays for each model and improves air circulation inside the blast chiller.
- 15 pairs of guides included.
- WIFI module included for the HACCP report download.

## Operation

### 2 available configurations:

- **Essential** This is the basic configuration that includes the most known functions of the blast chiller: cooling, rapid freezing, cold storage and non-stop cooling and freezing; regardless of the product introduction temperature, it always guarantees excellent results in terms of quality and uniformity of temperature in the cell.
- **Excellence** The multi-function configuration including 12 functions. In addition to the cold functions present in the Essential configuration, you will find: hot preservation, defrosting, ready-to-serve, low-temperature cooking, chocolate melting, leavening, pasteurization and drying.
  - MF Next's cooling cycles lower to +3°C the core temperature of the food, introduced at any temperature, even as soon as it is out of the oven, and quickly cross the band of maximum bacterial proliferation, the cause of their natural ageing.
  - MF Next's freezing cycles transform the water contained in food into microcrystals that preserve its structure and quality for longer.
  - Automatic recognition of manual work mode (timed) or automatic mode (with probe).

### 4 available performance levels

- **Standard:** this performance guarantees a yield of 50 kg in cooling and freezing. In the Essential function, performance is guaranteed by the evaporator and one-speed condenser fans (AC) and by airtight piston compressors. Combined with the Excellence function, the Standard performance makes use of the 5-speed "EC" Electronic Evaporator Fans. Climate class 4 (30°C ambient);
- **Turbo:** this performance increases the cooling and freezing capacity by up to 30%, thanks to the use of the 5-speed "EC" Electronic Evaporator Fans, which manage temperatures from -40° to +85°C, Scroll compressors and one-speed condenser fan. With climate class 5, it guarantees excellent performance above 40°C ambient;
- **Eco Silent:** this performance guarantees a yield of 50 kg in cooling and freezing with a very low level of noise emissions, thanks to the use of both electronic 5-speed evaporator fans (EC), which manage temperatures from -40°C to +85°C, and to the variable speed "EC" electronic condenser fans. Climate class 4 (30°C ambient);
- **Turbo Silent:** this performance increases the cooling and freezing capacity by up to 30% with a very low level of sound emissions, thanks to the use of the 5-speed "EC" Electronic Evaporator Fans, which manage temperatures from -40° to +85°C, Scroll compressors and variable-speed "EC" electronic condenser fan. With climate class 5, it guarantees excellent performance above 40°C ambient.

## Interface

**4.3' display** with capacitive screen, white LED bar to follow the progress of the cycle in progress even from a distance. With acoustic signal with adjustable intensity and fixed tone.

**10' display** with capacitive screen, RGB colour LED bar to follow the progress of the cycle in progress even from a distance. With acoustic signal with adjustable intensity and fixed tone.

- Dashboard customizable with the cycles selected by the customer.
- Ability to customize and/or create new cycles.
- Cycle library with all the cycles created by Irinox and the customer.
- Calendar for planning the cycles, with relative notification and the possibility of starting or postponing them.

## Connectivity

FreshCloud® is Irinox's IOT technology that allows you to control and interact with MultiFresh® Next at any time via an APP. The application features are:

- Remote monitoring of the operation and parameters of the cycle in progress
- Remote parameter modification (ventilation, cabinet temperature, core probe temperature, humidity level, phase duration)
- Remote start of the pre-cooling or pre-heating phases
- Push notification system
- Usage statistics viewing
- HACCP data backup
- Transfer and import of cycle libraries to other blast chillers.

## Optional

- Humidification kit to manage 6 levels of humidity consisting of a humidity detection sensor and a nozzle that atomises the humidity inside the blast chiller.
- Sanigen® (Irinox patented sanitization system).
- Water condensation (available only for Turbo performance)
- WIFI printer with 1300 thermal label roll
- Door opening on the right with hinges on the right
- 115° opening for side-by-side machines, shockproof (on request).
- 4 wheels, 2 of which with brake.
- Pair of additional GN1/1 and 600x400 mm guides
- Vacuum probe
- Special voltages on request
- Ethernet board
- Packing in HT wooden case.

## Product warranty

- 2 years from the date of installation, after sending the installation report, on the parts (see warranty condition).

## MF NEXT L

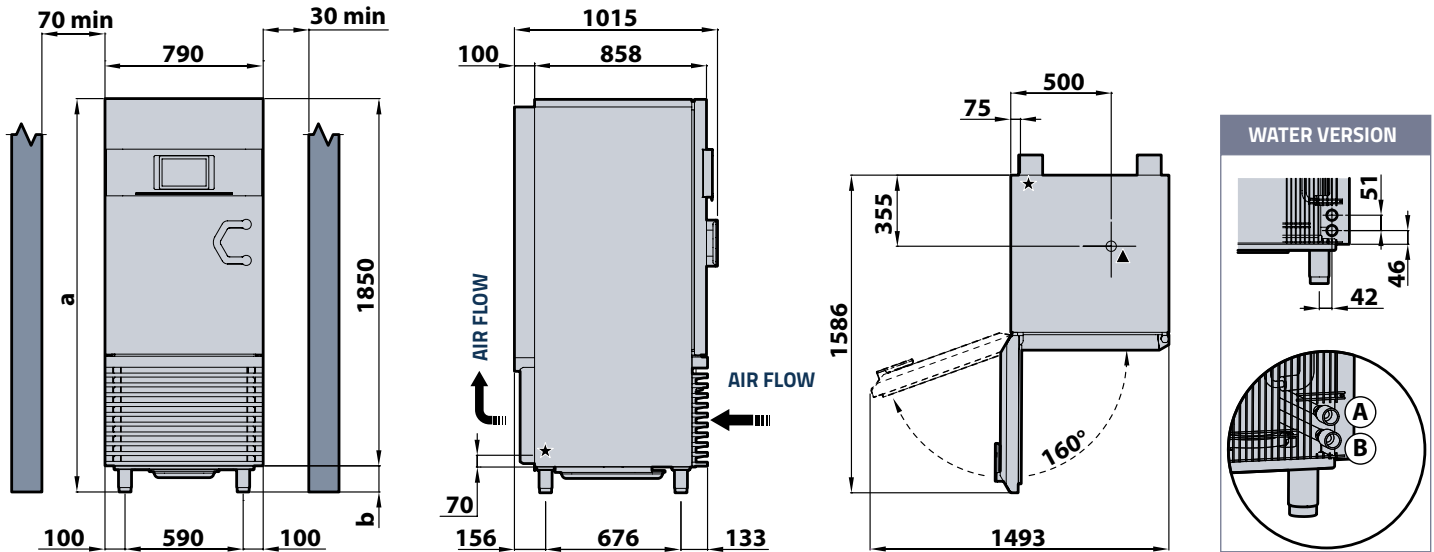

### HEIGHT

		a	b
Standard feet	mm	1965	115 ± 165
Lowered feet option	mm	1930	80 ± 115
Wheel option	mm	2005	155

Measurement in millimeters

★ Main power cable

▲ Drain pipe (corrugated flexible hose Ø32mm)

Ⓐ Water outlet

Ⓑ Water inlet

### TECHNICAL DATA

		380-415V-3N 50Hz				
		STANDARD	ECO SILENT	TURBO	TURBO SILENT	WATER
Electric supply	-	380-415V-3N 50Hz				
Performance						
Power rating	W	2774	3074	8003	8257	7757
Full load amps (FLA)	A	12,73	13,95	17,20	18,30	16,10
LOW TEMP COOKING power	W	2700	2700	2700	2700	2700
LOW TEMP COOKING amps	A	12,68	12,68	12,68	12,68	12,68
Main power cable	mm <sup>2</sup>	5G2.5	5G2.5	5G2.5	5G2.5	5G2.5
Refrigeration yield (-10/+40°C; Tsuct +20°C; Subcooling OK)	W	5040	5040	9510	9510	9510
Condenser rating (-5/+45°C; Tsuct+20°C; Subcooling OK)	W	8010	8010	14550	14550	14550
Minimum air exchange	m <sup>3</sup> /h	3350	3350	5000	5000	-
IN/OUT water connections	NPTf	-	-	-	-	1"
MAX water consumption (IN temp +30°C/ OUT temp +35°C)	l/h	-	-	-	-	2592
MIN/MAX inlet water temperature (water loop)	°C	-	-	-	-	+10 / +22 °C
MIN/MAX inlet water temperature (water tower)	°C	-	-	-	-	+23 / +35 °C
Refrigerant type	-	R290				
Nominal refrigerant charge	kg	3 x 0,15				
Climate class	-	4	4	5	5	5
Cabinet weight	kg	205	205	240	240	-
Noise (5 m)	dB(A)	60	-	-	-	-

### ENERGY CONSUMPTION ACCORDING TO EN 17032

Model	MF_NEXT_L (400V-3N+PE 50Hz)					
Type of product	Blast chiller / Blast freezer					
Performance		STANDARD	ECO SILENT	TURBO	TURBO SILENT	WATER
Yield per cycle	kg	45	45	75	75	75
Energy consumption Blast chilling cycle (STRONG +3 °C)	kWh/kg	0,066	-	0,081	-	-
Energy consumption Blast freezing cycle (STRONG -18 °C)	kWh/kg	0,186	-	0,256	-	-
Blast chilling cycle from/to +65 °C / +10 °C	min	72	-	70	-	-
Blast freezing cycle from/to +65 °C / -18 °C	min	224	-	246	-	-

#### INSTALLATION

The blast chiller must be installed by following and complying with the contents of the specific installation manual

The content of the manual must be carefully followed to ensure correct operation and to protect the rights of the user based on the warranty.

Continuous product development may require changes to specifications without notice.

#### Irinox SpA

Headquarter: Via Madonna di Loreto, 6/B - 31020 - Corbanese di Tarzo (TV) Italy

Productive Site: Via Mattei, 20 - 31029 - Vittorio Veneto (TV) Italy

Tel. +39 0438 2020 | irinox@irinox.com | www.irinoxprofessional.com