

**Warewashing
 green&clean dual rinse rack type,
 Energy Saving Device,ZERO LIME,Wash-
 Safe Control 250r/h, elec-50Hz**

ITEM # _____

MODEL # _____

NAME # _____

SIS # _____

AIA # _____



535106 (EDR25PERA5WV) Dual rinse rack type dishwasher, 250 racks/hour, Energy Saving Device, ZERO LIME Device, CLEAR BLUE Filtering System, WASH-SAFE CONTROL, electric, touch screen, Right> Left

535107 (EDR25PELA5WV) Dual rinse rack type dishwasher, 250 racks/hour, Energy Saving Device, ZERO LIME Device, CLEAR BLUE Filtering System, WASH-SAFE CONTROL, electric, touch screen, Left> Right

Short Form Specification

Item No. _____

Unit to be Electrolux green&cleand dual rinse rack type dishwasher. Operating direction right to left or left to right. Featured built-in Energy Saving Device (ESD) recovers the heat inside the machine to heat up incoming cold water to the boiler. Dual rinse with built-in WASH-SAFE CONTROL system and rinse booster pump guarantees constant rinse pressure. ZERO LIME device automatically de-scales the whole hydraulic circuit and all washing and rinsing chambers. Maximum Water Contact (MWC) wash arms are positioned along the full length of the wash tank included large pre-wash zone works with cold water of max. 40°C. Powerful wash pump and specially designed wash spray arms guarantee cleaning. Washing is done with water circulating at 55-65°C. Final rinsing is done with clean water heated up to 85°C. Dual rinse technology provides rinse water covering maximum the rinse area to ensure hygiene on washed wares. Low rinse water consumption of 1 liters per rack at maximum speed of 250racks/hour. Three conveyor speeds are selectable by the operator with maximum capacity of 250racks/hour. Intuitive touch screen control panel provides easy communication on different levels. Large counter-balance door has heat and noise insulation with easy internal access. CLEAR BLUE filtering system removes majority of soil from the wash water to ensure clean water for long time. Built-in drain valve in the tank allows automatic dump and fill to refresh the water in the tank without interruption. Standard end of the day self cleaning cycle and sanitation cycle. Modularity allows split delivery, customization and upgrade on-site and over time.

Main Features

- ZERO LIME Device as a fully automatic cycle ensures total scale removal from the boiler, the hydraulic circuit, the washing chamber and the rinsing chamber allowing ultimate performances and lower energy consumption thanks to highly efficient heating elements.
- IP25 protection against water jets, solid objects and small animals (larger than 6 mm).
- Auto-start/stop equipped in different zones ensures that the zone runs only when a rack is passing through it. This reduces water, energy, chemical consumption and noise.
- Intuitive touch screen control panel features user-friendly display to easily operate the machine and to monitor machine status. Three different levels of interaction are available each show relevant messages and information to the operator, the general maintenance staff and the authorized service partners.
- All internal components: wash and rinse arms, tank filters, curtains can be easily removed for cleaning.
- Unit equipped with USB port making it simple to read data such as machine identification, counters and consumption, components, devices and alarm logs. Machine parameters can be uploaded and downloaded and firmware updated.
- Built-in drain valve in the tanks allows automatic dump and fill to refresh the water in the tank without any interruption of the washing process.
- CLEAR BLUE filtering system removes soil from the wash water providing cleaner water and highly active detergent thus ensuring better washing performance and lower running costs.
- Pre-wash section uses cold water so food remains are not "baked" onto the plates in order to have better pre-wash performance.
- Adjustable feet for full access underneath the machine for cleaning.
- Large counter balanced inspection door allow unrestricted all-round access to the wash and rinse area. Door is insulated with injected foam. This adds strength as well as reduces noise and heat loss.
- Built-in stabilized pressure valve ensures constant pressure throughout the rinsing cycle regardless of inlet water pressure.
- Automatic drain, clean and sanitize cycles featured as standard. The internal chamber, is completely cleaned or sanitized avoiding bacteria proliferation for maximum hygiene and reducing manual work/time for operator.
- Self-draining vertical wash pumps provide maximum hygiene.
- Automatic back-up mode is activated when a failure occurs. Guided troubleshooting for fast fixes including 150 precises notifications and 23 easy-to-follow processes.
- Three conveyor speeds can be selected through the control panel by the operator and customized on-site.
- The unit is ready to be connected with OnE Connectivity for 24/7 real time monitoring,

APPROVAL: _____

**Warewashing
 green&clean dual rinse rack type, Energy Saving Device,ZERO LIME,
 Wash-Safe Control 250r/h, elec-50Hz**



increasing equipment uptime, maximum profit and optimizing your process.

- Maximum capacity per hour of 250 racks easy to switch to DIN 10510 compliant or other speed.
- Built-in WASH-SAFE CONTROL system raises water temperature to 85°C to sanitize the rinse water. No external boiler is required. Built-in air break and rinse booster pump ensure constant temperature and pressure throughout the rinsing cycle regardless of the inlet water condition.
- Built-in Energy Saving Device (ESD) captures the hot steam released on the sides of the machine to heat up incoming cold water before entering to the boiler, thus saving energy and reducing heat emission from the machine.
- Dual rinse with air break and rinse booster pump guarantees rinse water consumption of 1.0 liters/rack regardless of inlet water pressure to ensure low energy, water, detergent and rinse aid consumption.

Construction

- Dishwasher structure is held together with a solid 50 x 50 mm stainless steel frame to provide long-term sturdiness.
- All electric components are put in one IP65 central box isolated from water and steam to ensure high reliability.
- External pre-arrangement for inlet water, drain water, detergent & rinse aid connections for fast and easy installation on both sides of the unit.
- All chambers without internal pipes and therefore no hidden dirt traps.
- All main components made in heavy duty anti-corrosive 304 type stainless steel: external front, side panels and internal chambers, wash and rinse arms, doors and rack transportation system.
- Modularity design allows the machine not only be disassembled for delivery and re-assembled at customer's site, but also to be customized and upgraded on-site and over time.
- Deep drawn pressed wash tank with fully rounded corners, sloped towards the drain to prevent dirt buildup, provides fast drainage in just a few minutes. With no welding points the pressed tank offers a guaranteed water tight solution.

Included Accessories

- 2 of Splash hood kit for single and dual rinse Rack Type Dishwasher, 200 mm PNC 865498

Optional Accessories

- Medium drying zone with door for green&clean Dual Rinse Rack Type Dishwasher PNC 535097
- Large drying zone with door for green&clean Dual Rinse Rack Type Dishwasher PNC 535098
- Corner drying zone for green&clean Dual Rinse Rack Type Dishwasher PNC 535099
- Medium hot air blower zone without door for Dual Rinse Rack Type Dishwasher, 50Hz & 60Hz PNC 535141
- Kit end limit switch for Rack Type dishwasher PNC 864138
- Connection bracket for plain undershelf and grid undershelf (to be used if roller conveyor is connected directly to Rack Type Dishwasher with splash hood) PNC 865235
- Kit water softener for Rack Type dishwasher PNC 865284
- Kit water meter PNC 865286
- HACCP cable connection for Rack Type dishwasher PNC 865490
- Kit water softener and reverse osmosis for Rack Type Dishwasher PNC 865494
- Silicon curtains for single and dual rinse Rack Type dishwasher PNC 865503
- Kit electronic connection for motorized table and remote pre wash module for Dual Rinse Rack Type Dishwasher PNC 865508
- Set of 6 baskets: 2 for trays, 2 for plates, 1 for cutlery and 1 for cups PNC 867050
- Set of 9 baskets: 2 for trays, 3 for plates, 2 for cutlery and 2 for cups PNC 867051
- Connectivity hub (LAN) PNC 922697
- Connectivity hub (SIM) PNC 922705



Electrolux
PROFESSIONAL

Warewashing
green&clean dual rinse rack type, Energy
Saving Device,ZERO LIME,Wash-Safe Control
250r/h, elec-50Hz

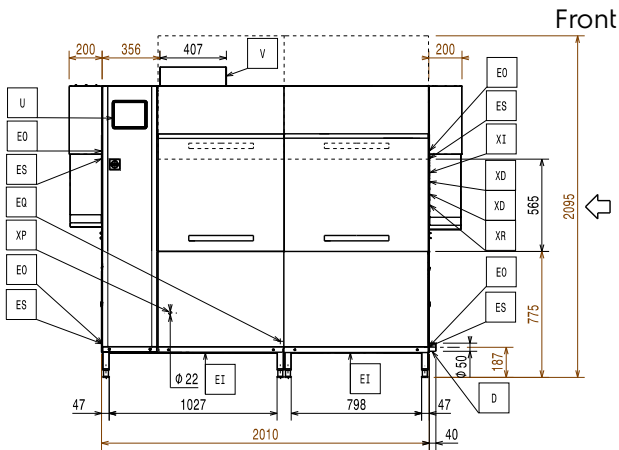

Front

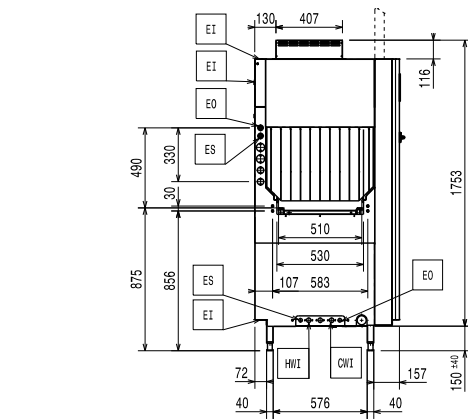

Side

- CWI = Cold Water Inlet
- D = Drain
- EI = Electrical inlet (power)
- EO = Electrical Outlet
- EQ = Equipotential screw
- ES = Electrical signal IN/OUT
- U = USB port
- WI = Water inlet

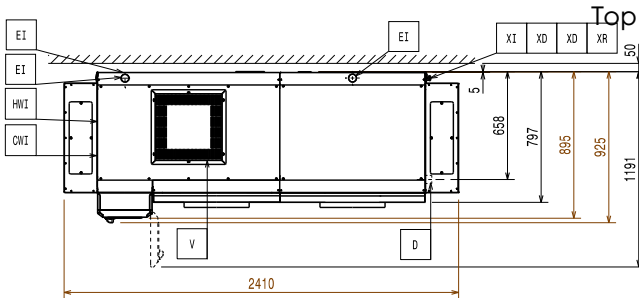

Top

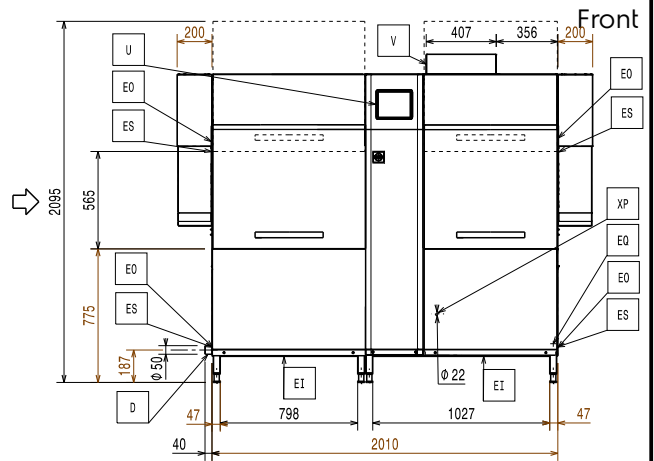

Front

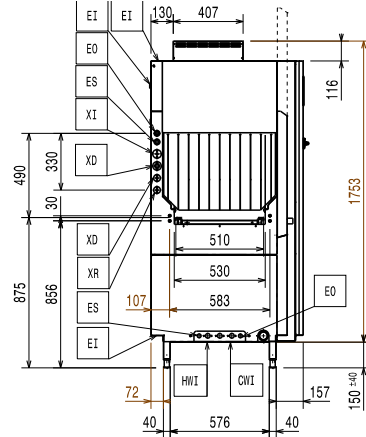

Side

- CWI = Cold Water Inlet
- D = Drain
- EI = Electrical inlet (power)
- EO = Electrical Outlet
- EQ = Equipotential screw
- ES = Electrical signal IN/OUT
- U = USB port
- WI = Water inlet

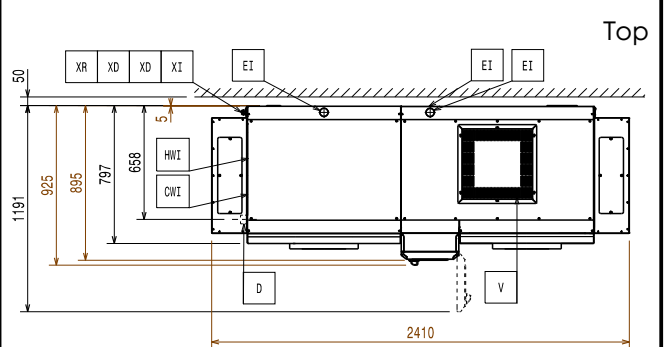

Top



Electric

Supply voltage:

535106 (EDR25PERA5WV)	380-415 V/3N ph/50 Hz
535107 (EDR25PELA5WV)	380-415 V/3N ph/50 Hz

Default Installed Power: 33 kW

Electrical power min: 23 kW

When the machine is run at DIN 10510 compliant speed.

Pre-wash tank heating elements:

7 kW

Pre-wash tank heating element are activated only during sanitation cycle.

Boiler heating elements: 19 kW

Wash pump size: 1.5kW

Wash tank heating elements: 10 kW

Water:

Inlet hot water line size: G 3/4"

Inlet cold water line size: G 3/4"

Drain line size: 50mm

Inlet water supply pressure: 1.5-6 bar

Inlet water supply temperature (wash): 50 - 65 °C

Inlet water supply hardness: 14 °fH / 8°dH

When below 7°fH/4°dH special detergent and rinse aid are needed.

Peak rate of drain flow: 2.5 l/s

Pre-wash tank size: 70 l

Water cold/hot pipe size G 3/4"

Rinse water consumption at max speed (l/rack): 1 l/rack

Rinse water consumption at max speed (l/h) 250 l/h

Key Information:

Productivity per hour (max. speed): 250 racks/4500dishes

Productivity per hour (medium speed): 168 racks/3024 dishes

Productivity per hour (DIN compliant speed): 115 racks/2070 dishes

Wash Temperature: 55 - 65 °C

Pre-wash temperature: 10-40°C

Final rinse temperature: 85 °C

External dimensions, Width: 2410 mm

External dimensions, Height: 1908 mm

External dimensions, Depth: 925 mm

For transportation purpose only, the depth can be reduced to either 895mm by removing the main switch button or 797mm by removing the control box and the door handle.

Height with door open: 2095 mm

Charging hole size (width): 530 mm

Charging hole size (height): 490 mm

Shipping height: 2068 mm

Shipping width: 1006 mm

Shipping depth: 2142 mm

Shipping volume: 4.46 m³

Noise level: <62 dBA

Reference norm used to measure the noise: IEC60335-2-58 annex AA.

Table to table distance: 2010 mm

Air Emission:

Air flow (top, exit): 565 / 0 m³/h

Air temperature (top, exit): 27 °C

Air humidity (top, exit): 100 / 0 % r.h.

The data is measured at exhaust points at 25°C and 60% r.h. ambient conditions, 18°C inlet water temperature and refer only to the machine.

Latent heat: 5000 W

This model requires a ventilation hood. Please refer to the attached "Recommended Exhaust Hood Design".

RECOMMENDED TABLE CONNECTION

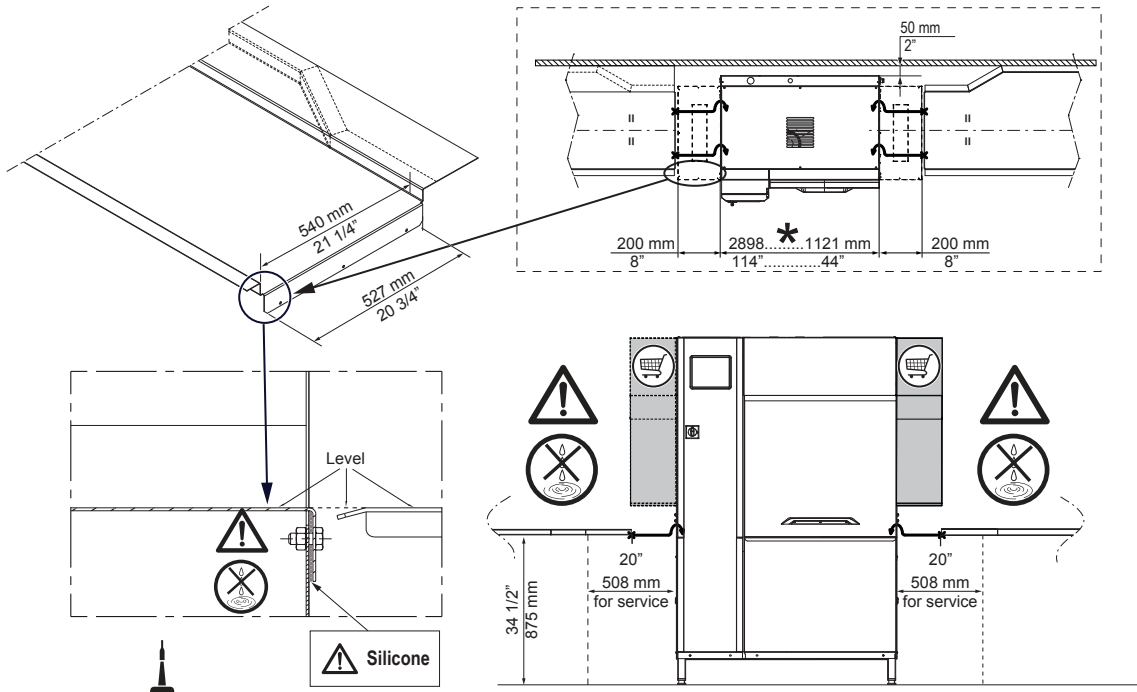

⚠ Apply silicone between the machine and the table and make sure that there are not any water leakages. Reference code 059611 for recommended silicone by Electrolux.

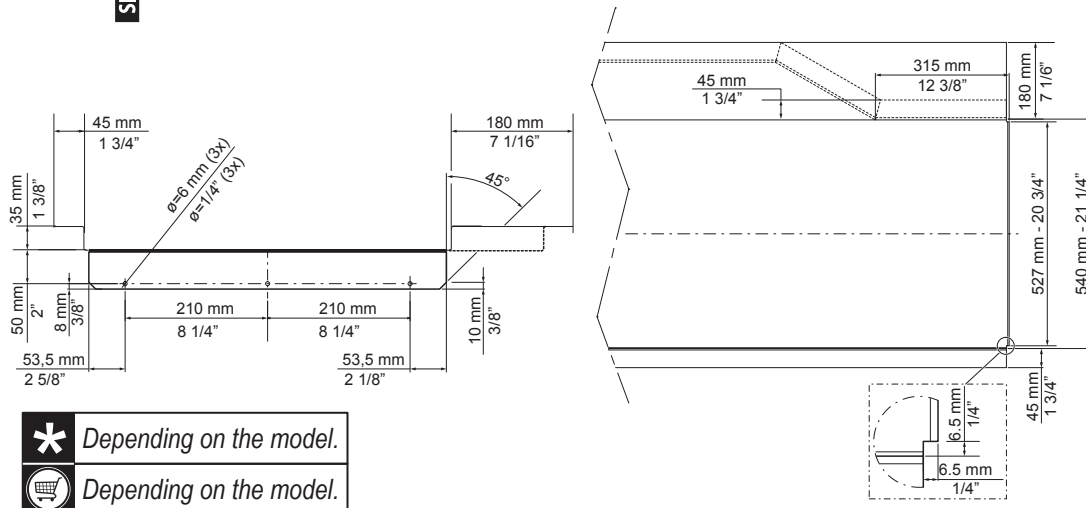

- Depending on the model.
- Depending on the model.

All tables must be connected to the dishwashing units according to local regulations and industry standards which may differ from the recommendations herein suggested. Electrolux Professional is not liable for any failure in complying with local design standards.

DOC. NO. 59566QD00
EDITION 01.2020