

**Warewashing  
 green&clean dual rinse rack type  
 dishwasher with Energy Saving Device,  
 150racks/hour, electric,50Hz**

ITEM # \_\_\_\_\_

MODEL # \_\_\_\_\_

NAME # \_\_\_\_\_

SIS # \_\_\_\_\_

AIA # \_\_\_\_\_

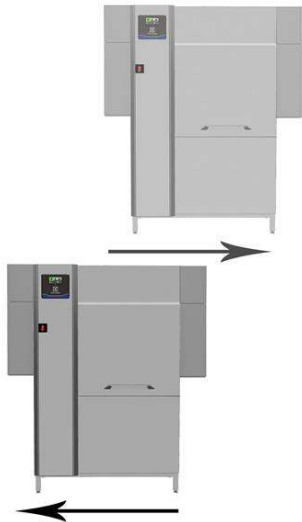
**535103 (EDR150ECA5WV)**

 Dual rinse rack type  
 dishwasher, 150 racks/hour,  
 Energy Saving Device,  
 ZERO LIME Device, CLEAR  
 BLUE Filtering System,  
 WASH-SAFE CONTROL,  
 electric, touch screen,  
 customized direction on-site

### Short Form Specification

**Item No.** \_\_\_\_\_

Unit to be Electrolux green&clean dual rinse rack type dishwasher. Featured built-in Energy Saving Device (ESD) recovers the heat inside the machine to heat up incoming cold water to the boiler. Dual rinse with built-in WASH-SAFE CONTROL system and rinse booster pump guarantees constant rinse pressure. ZERO LIME device automatically de-scales the whole hydraulic circuit and all washing and rinsing chambers. Maximum Water Contact (MWC) wash arms are positioned along the full length of the wash tank. Powerful wash pump and specially designed wash spray arms guarantee cleaning. Washing is done with water circulating at 55-65°C. Final rinsing is done with clean water heated up to 85°C. Dual rinse technology provides rinse water covering maximum the rinse area to ensure hygiene on washed wares. Low rinse water consumption of 1.2liters per rack at maximum speed of 150racks/hour. Three conveyor speeds are selectable by the operator with maximum capacity of 150racks/hour. Intuitive touch screen control panel provides easy communication on different levels. Large counter-balance door has heat and noise insulation with easy internal access. CLEAR BLUE filtering system removes majority of soil from the wash water to ensure clean water for long time. Built-in drain valve in the tank allows automatic dump and fill to refresh the water in the tank without interruption. Standard end of the day self cleaning cycle and sanitation cycle. Operating direction of the machine is decided by customer on-site depending on the layout flow with pre-arranged right to left from the factory.

### Main Features

- ZERO LIME Device as a fully automatic cycle ensures total scale removal from the boiler, the hydraulic circuit, the washing chamber and the rinsing chamber allowing ultimate performances and lower energy consumption thanks to highly efficient heating elements.
- IP25 protection against water jets, solid objects and small animals (larger than 6 mm).
- Auto-start/stop equipped in different zones ensures that the zone runs only when a rack is passing through it. This reduces water, energy, chemical consumption and noise.
- Intuitive touch screen control panel features user-friendly display to easily operate the machine and to monitor machine status. Three different levels of interaction are available each show relevant messages and information to the operator, the general maintenance staff and the authorized service partners.
- All internal components: wash and rinse arms, tank filters, curtains can be easily removed for cleaning.
- Unit equipped with USB port making it simple to read data such as machine identification, counters and consumption, components, devices and alarm logs. Machine parameters can be uploaded and downloaded and firmware updated.
- Large counter balanced inspection door allow unrestricted all-round access to the wash and rinse area. Door is insulated with injected foam. This adds strength as well as reduces noise and heat loss.
- Self-draining vertical wash pumps provide maximum hygiene.
- Automatic back-up mode is activated when a failure occurs. Guided troubleshooting for fast fixes including 150 precises notifications and 23 easy-to-follow processes.
- Adjustable feet for full access underneath the machine for cleaning.
- Built-in drain valve in the tanks allows automatic dump and fill to refresh the water in the tank without any interruption of the washing process.
- CLEAR BLUE filtering system removes soil from the wash water providing cleaner water and highly active detergent thus ensuring better washing performance and lower running costs.
- Automatic drain, clean and sanitize cycles featured as standard. The internal chamber, is completely cleaned or sanitized avoiding bacteria proliferation for maximum hygiene and reducing manual work/time for operator.
- Dual rinse technology ensures maximum rinse water covering every corner of the rack inside the rinse area for perfect hygiene on washed wares.
- Three conveyor speeds can be selected through the control panel by the operator and customized on-site.
- The unit is ready to be connected with OnE Connectivity for 24/7 real time monitoring, increasing equipment uptime, maximum profit and optimizing your process.
- Maximum capacity per hour of 150 racks easy to

**APPROVAL:** \_\_\_\_\_

**Warewashing  
 green&clean dual rinse rack type dishwasher with Energy Saving  
 Device, 150racks/hour, electric,50Hz**



switch to DIN 10510 compliant or other speed.

- Built-in WASH-SAFE CONTROL system raises water temperature to 85°C to sanitize the rinse water. No external boiler is required. Built-in air break and rinse booster pump ensure constant temperature and pressure throughout the rinsing cycle regardless of the inlet water condition.
- Built-in Energy Saving Device (ESD) captures the hot steam released on the sides of the machine to heat up incoming cold water before entering to the boiler, thus saving energy and reducing heat emission from the machine.
- Dual rinse with air break and rinse booster pump guarantees rinse water consumption of 1.2 liters/rack regardless of inlet water pressure to ensure low energy, water, detergent and rinse aid consumption.

### Construction

- Deep drawn pressed wash tank with fully rounded corners, sloped towards the drain to prevent dirt buildup, provides fast drainage in just a few minutes. With no welding points the pressed tank offers a guaranteed water tight solution.
- Dishwasher structure is held together with a solid 50 x 50 mm stainless steel frame to provide long-term sturdiness.
- All electric components are put in one IP65 central box isolated from water and steam to ensure high reliability.
- External pre-arrangement for inlet water, drain water, detergent & rinse aid connections for fast and easy installation on both sides of the unit.
- All chambers without internal pipes and therefore no hidden dirt traps.
- All main components made in heavy duty anti-corrosive 304 type stainless steel: external front, side panels and internal chambers, wash and rinse arms, doors and rack transportation system.
- The feeding direction is right to left as pre-arrangement from the factory, but it can be simply reversed on-site to left to right.
- Modularity design allows the machine not only be disassembled for delivery and re-assembled at customer's site, but also to be customized and upgraded on-site and over time.
- The unit is built on modularity concept for easy to add pre-wash and dryer modules on-site.

### Included Accessories

- 2 of Splash hood kit for single and dual rinse Rack Type Dishwasher, 200 mm PNC 865498

### Optional Accessories

- Medium pre-wash zone for green&clean Dual Rinse Rack Type Dishwasher PNC 535095
- Large pre-wash zone for green&clean Dual Rinse Rack Type Dishwasher PNC 535096
- Medium drying zone with door for green&clean Dual Rinse Rack Type Dishwasher PNC 535097
- Large drying zone with door for green&clean Dual Rinse Rack Type Dishwasher PNC 535098
- Corner drying zone for green&clean Dual Rinse Rack Type Dishwasher PNC 535099
- Medium hot air blower zone without door for Dual Rinse Rack Type Dishwasher, 50Hz & 60Hz PNC 535141
- Kit end limit switch for Rack Type dishwasher PNC 864138
- Connection bracket for plain undershelf and grid undershelf (to be used if roller conveyor is connected directly to Rack Type Dishwasher with splash hood) PNC 865235
- Kit water softener for Rack Type dishwasher PNC 865284
- Kit water meter PNC 865286
- HACCP cable connection for Rack Type dishwasher PNC 865490
- Kit water softener and reverse osmosis for Rack Type Dishwasher PNC 865494
- Silicon curtains for single and dual rinse Rack Type dishwasher PNC 865503
- Kit electronic connection for motorized table and remote pre wash module for Dual Rinse Rack Type Dishwasher PNC 865508
- Kit extend pipe for ESD of Dual Rinse Rack Type Dishwasher PNC 865509
- Set of 6 baskets: 2 for trays, 2 for plates, 1 for cutlery and 1 for cups PNC 867050
- Set of 9 baskets: 2 for trays, 3 for plates, 2 for cutlery and 2 for cups PNC 867051
- Connectivity services hub (router) PNC 922697
- Connectivity services hub (router for sim card) PNC 922705



**Electric**

<b>Supply voltage:</b>	
535103 (EDR150ECA5WV)	380-415 V/3N ph/50 Hz
<b>Default Installed Power:</b>	26.5 kW
<b>Electrical power min:</b>	16.5 kW
When the machine is run at DIN 10510 compliant speed.	
<b>Boiler heating elements:</b>	14 kW
<b>Wash pump size:</b>	1.5kW
<b>Wash tank heating elements:</b>	10 kW

**Water:**

<b>Inlet hot water line size:</b>	G 3/4"
<b>Inlet cold water line size:</b>	G 3/4"
<b>Drain line size:</b>	50mm
<b>Inlet water supply pressure:</b>	1.5-6 bar
<b>Inlet Water Supply temperature (rinse):</b>	10-30°C
<b>Inlet water supply temperature (wash):</b>	50 - 65 °C
<b>Inlet water supply hardness:</b>	14 °fH / 8°dH
When below 7°fH/4°dH special detergent and rinse aid are needed.	
<b>Peak rate of drain flow:</b>	2.5 l/s
<b>Wash tank size:</b>	70 l
<b>Rinse water consumption at max speed (l/rack):</b>	1.2 l/rack
<b>Rinse water consumption at max speed (l/h)</b>	180 l/h

**Key Information:**

<b>Productivity per hour (max. speed):</b>	150 racks/2700dishes
<b>Productivity per hour (medium speed):</b>	114 racks/2052 dishes
<b>Productivity per hour (DIN compliant speed):</b>	82 racks/1476 dishes
<b>Wash Temperature:</b>	55 - 65 °C
<b>Final rinse temperature:</b>	85 °C
<b>External dimensions, Width:</b>	1520 mm
<b>External dimensions, Height:</b>	1908 mm
<b>External dimensions, Depth:</b>	925 mm
For transportation purpose only, the depth can be reduced to either 895mm by removing the main switch button or 797mm by removing the control box and the door handle.	
<b>Height with door open:</b>	2095 mm
<b>Charging hole size (width):</b>	530 mm
<b>Charging hole size (height):</b>	490 mm
<b>Shipping height:</b>	2070 mm
<b>Shipping width:</b>	1010 mm
<b>Shipping depth:</b>	1260 mm
<b>Shipping volume:</b>	2.63 m <sup>3</sup>
<b>Noise level:</b>	<62 dBA
Reference norm used to measure the noise: IEC60335-2-58 annex AA.	
<b>Table to table distance:</b>	1120 mm

**Air Emission:**

<b>Air flow (top, exit):</b>	565 / 0 m <sup>3</sup> /h
<b>Air temperature (top, exit):</b>	27 °C
<b>Air humidity (top, exit):</b>	100 / 0 % r.h.
The data is measured at exhaust points at 25°C and 60% r.h. ambient conditions, 18°C inlet water temperature and refer only to the machine.	
<b>Latent heat:</b>	5000 W
<b>Sensible heat:</b>	2100 W
This model requires a ventilation hood. Please refer to the attached "Recommended Exhaust Hood Design".	

**RECOMMENDED TABLE CONNECTION**

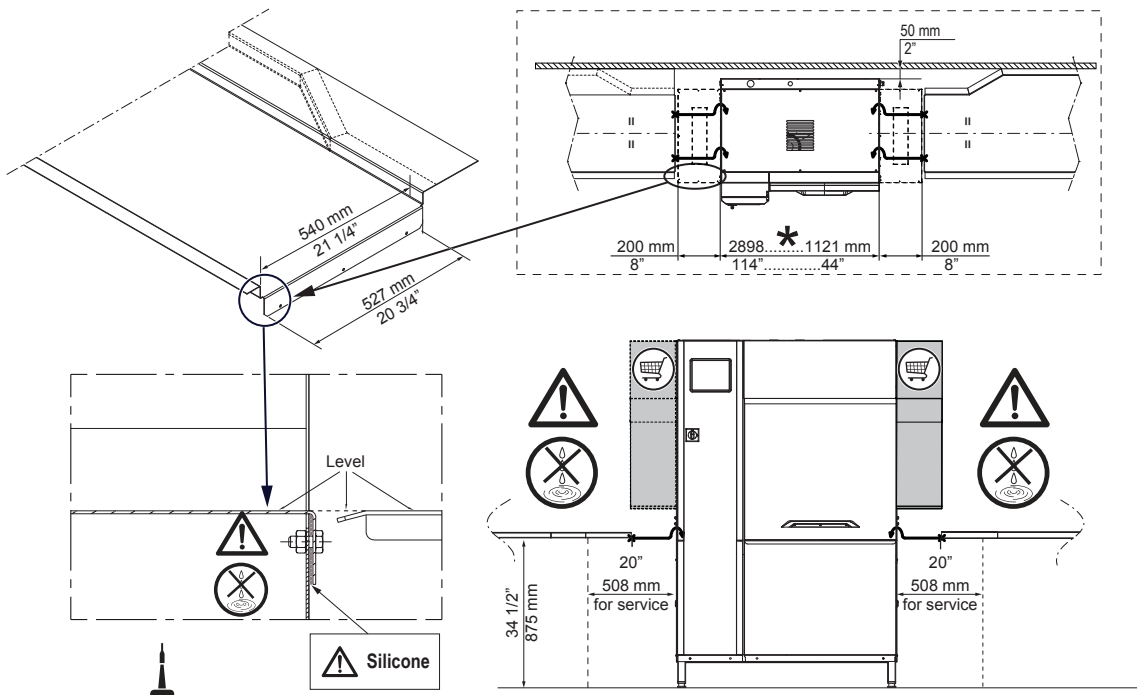

**⚠ Apply silicone between the machine and the table and make sure that there are not any water leakages. Reference code 059611 for recommended silicone by Electrolux.**

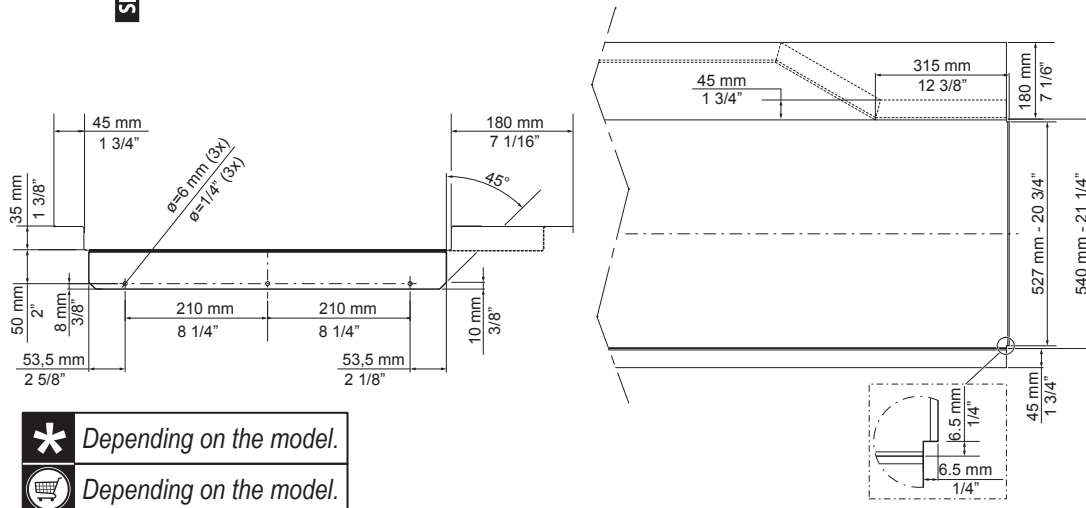

- Depending on the model.
- Depending on the model.

All tables must be connected to the dishwashing units according to local regulations and industry standards which may differ from the recommendations herein suggested. Electrolux Professional is not liable for any failure in complying with local design standards.

DOC. NO. 59566QD00  
EDITION 01.2020