

**Warewashing
 Undercounter, atmospheric boiler,
 double skin, drain pump, det&rinse aid
 disp, 720d/h - Caf e line**

ITEM # _____

MODEL # _____

NAME # _____

SIS # _____

AIA # _____

502720 (ELA11GCL)

Undercounter Dishwasher with atmospheric boiler, double skin, built-in drain pump, detergent and rinse aid dispensers, 1 phase, 720d/h - Caf e line

Short Form Specification

Item No. _____

Unit shall be Electrolux Professional green&clean Caf e-line undercountertype hot water rinsing dishmachine using rack dimension of 500*500mm. Electrical characteristics to be 230 volts single phase 50Hz operation, convertible to three phase on-site. Washing performance is ensure by a powerful wash pump, large capacity wash tank, upper and lower revolving spray arms. Soft start wash pump to avoid accidental breakage of crystal wares. Constant rinse temperature and pressure guaranteed by built-in atmospheric boiler and rinse booster pump. Uses 2.5 liters of clean water per final rinse. Powerful boiler heater ensures high productivity even with cold water supply. Three automatic cycles for different types of wares. Double skin insulated, counter-balance door. Double skin cabinet. Pressed wash tank with round corners. 304 AISI stainless steel construction to include door, external panels, frame, wash tank, tank filters, wash arms and rinse arms. The unit shall include drain pump, detergent and rinse aid dispenser pumps and is equipped with electric cable. Delivered small castors for easily moving the machine around.

Main Features

- Incorporated Soft Start feature to offer additional protection to more delicate items.
- Washing system endowed with rotating washing arms, high powered wash pump and large capacity boiler for professional washing.
- 4 second (variable) pause after washing and before rinsing ensures that no drops of unclean water will fall on the clean items at the end of the rinsing cycle.
- Fully automatic self-cleaning cycle avoids the risk of bacteria proliferation.
- Simple control panel with digital display allows on-site personalization of washing and rinsing cycle times and temperatures as well as precise rinse aid and detergent quantities to suit customer's needs.
- Simple service from the front.
- IPx4 water protection.
- Pre-arrangement for HACCP system implementation and Energy Management device.
- Digital read-out keeps operator informed as to temperatures.
- State-of-the-art electronic controls with built-in programming, self-diagnostics for serviceability and automatic interior self-cleaning cycle.
- Unique temperature interlock guarantees required temperatures in both the wash and final rinse.
- Constant temperature of 84  C throughout the rinsing cycle regardless of the network's water pressure and temperature.
- Double skinned insulated wall ensures a low noise level and a reduction in heat loss from the machine.
- High efficiency air gap (class A) in water inlet circuit to avoid water being siphoned back into the network as a result of a sudden drop in main pressures.
- Low noise level.
- Washing capacity of 40 baskets or 720 dishes per hour.
- Slanted wash arms to avoid detergent-filled wash water dropping on clean dishes after the rinsing phase, thus guaranteeing ideal washing results.
- Built-in atmospheric boiler sized to raise incoming water to 84  C minimum for sanitizing rinse. No external booster is required.
- Solid double skinned counter-balance door with hurt-free handle fully in stainless steel.
- An effective rinse system uses only 2,5 litres of clean hot water per basket for lower running costs.
- Built-in rinse aid and detergent dispenser with automatic initial and continuous cycle loading for perfect result while minimizing service and maintenance needs.
- Three phase or single phase electrical connection, convertible on-site.

Construction

- Unit to feature smooth surfaces to facilitate cleaning.
- 304 stainless steel boiler with higher welding protection to increase resistance to corrosion.

APPROVAL: _____

- PVC water supply hose with metal connections resistant to high water pressure.
- Completely closed on the back by a cover plate.
- Element protection from dry fire and low water.
- Interchangeable wash/rinse arms screw out for simple clean up.
- The boiler drain facilitates the evacuation of stagnant water after long periods of inactivity to ensure a higher level of hygiene.
- Incorporated drain pump to control water level in wash tank draining.
- Large deep drawn wash tank and internal wash area with round corners and no pipes to avoid dirt built-up.
- Revolving Stainless steel wash/rinse arms above and below the basket.
- Large tank filter collects the soil to keep the wash water clean for a longer time and have better washing performance.
- Front panel, door, wash tank, tank filters, wash arms and rinse arms made in heavy duty anti-corrosive 304 AISI stainless steel.
- Unit to feature drain pump, rinse aid and detergent dispenser pumps.
- 4 rollers under the machine to allow it to be easily extracted for cleaning.

- Half size basket for glasses PNC 864529
- Kit 4 plastic boxes for cutlery - yellow PNC 865574
- Basket for 18 dinner plates - yellow PNC 867002
- Basket for 5 trays 530x325 mm - red, for undercounter (top level), utensil dishwashers, hood type, rack type PNC 867006
- Basket for 48 small cups or 24 cups - blue PNC 867007
- Wire basket for 12 plates up to 320 mm PNC 867014
- Cover rack for small and light items (500x500 baskets) PNC 867016
- Basket for long stem wine glasses PNC 867019
- Basket for 16 vertical glasses (h 70 mm - diam 100 mm) - blue PNC 867023
- Basket semi-professional 500x500x190mm PNC 867024

Included Accessories

- 2 of Yellow cutlery container PNC 864242
- 1 of Basket for 18 dinner plates - yellow PNC 867002
- 1 of Basket for 48 small cups or 24 cups - blue PNC 867007

Optional Accessories

- 12lt external manual water softener PNC 860412
- 8lt external automatic water softener PNC 860413
- Stand for undercounter dishwasher PNC 860418
- 20lt external manual water softener PNC 860430
- Integrated HACCP kit PNC 864001
- Kit 4 castors for double skin undercounter dishwashers PNC 864008
- KIT 4 FLANGED FEET (MARINE FEET) FOR UC DW PNC 864009
- Filter for partial demineralization PNC 864017
- Kit to measure total and partial water hardness PNC 864050
- Yellow cutlery container PNC 864242
- Filter for total demineralization PNC 864367
- Reverse osmosis filter for single tank Dishwasher with atmosphere boiler PNC 864388
- Pressure reducer for single tank dishwasher PNC 864461
- Half size basket universal PNC 864527
- Half size basket for plates PNC 864528

Front

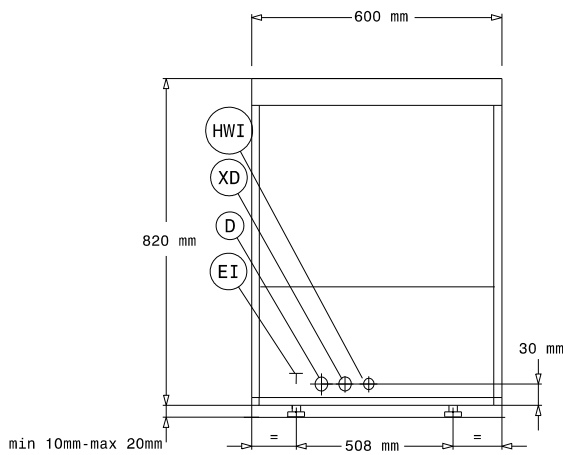

Side

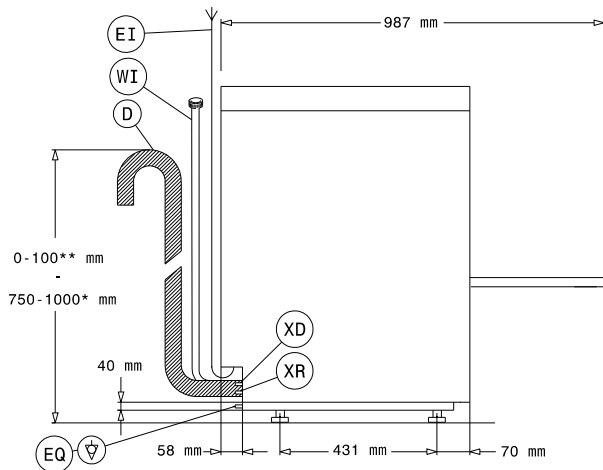

- D = Drain
- EI = Electrical inlet (power)
- EO = Electrical Outlet
- HWI = Hot water inlet
- XD = Detergent connection
- XR = Rinse aid connection

Top

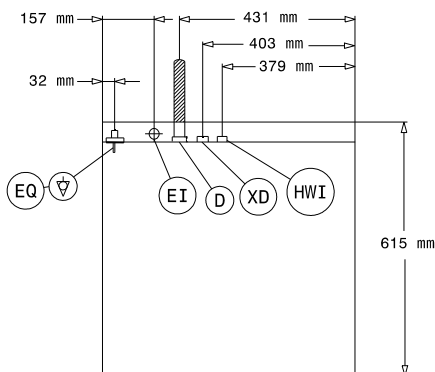

Electric

| | | |
|---------------------------------|-------------------|-------------------|
| Supply voltage: | 502720 (ELAI1GCL) | 230 V/1 ph/50 Hz |
| Convertible to: | | 400V 3N~; 230V 3~ |
| Default Installed Power: | | 6.85 kW |
| Boiler heating elements: | | 6 kW |
| Tank heating elements: | | 2 kW |
| Wash pump size: | | 0.736 kW |

Water:

| | |
|--|---------------------------|
| Pressure, bar min/max: | 0.5-7 bar |
| Water supply temperature*: | 50 °C |
| Drain line size: | 20.5mm |
| Inlet Water supply pressure: | 7 - 102 psi (0.5 - 7 bar) |
| Washing tank capacity (lt): | 23 |
| Water consumption per cycle (lt): | 2.5 |
| Boiler Capacity (lt): | 12 |

Key Information:

| | |
|-------------------------------------|----------------|
| Baskets per hour*: | 40 |
| Dishes per hour: | 720 |
| Working cycles time (sec.): | 90/120/240 |
| Wash temperature: | 55-65°C |
| Cell dimensions - width: | 500 mm |
| Cell dimensions - depth: | 500 mm |
| Cell dimensions - height: | 335 mm |
| Rinse temperature: | 84 °C |
| External dimensions, Width: | 600 mm |
| External dimensions, Height: | 820 mm |
| External dimensions, Depth: | 615 mm |
| Packaging size (WxDxH): | 690x620x920 mm |
| Noise level: | 61 dBA |