

SkyLine ProS Natural Gas Combi Oven 20GN2/1

ITEM # _____

MODEL # _____

NAME # _____

SIS # _____

AIA # _____

227665 (ECOE202K2U0)

SkyLine ProS combi boilerless oven with touch screen control, 20x2/1GN, gas, 2 cooking modes (recipe program, manual), automatic cleaning

Short Form Specification

Item No. _____

Combi oven with high resolution full touch screen interface, multilanguage.

- Boilerless steaming function to add and retain moisture.
- OptiFlow air distribution system to achieve maximum performance with 7 fan speed levels.
- SkyClean: Automatic and built-in self cleaning system. 5 automatic cycles (soft, medium, strong, extra strong, rinse-only) and green functions to save energy, water, detergent and rinse aid.
- Cooking modes: Programs (a maximum of 1000 recipes can be stored and organized in 16 different categories); Manual (steam, combi and convection cycles); EcoDelta cooking cycle.
- Special functions: MultiTimer cooking, Plan-n-Save to cut running costs, Make-it-Mine to customize interface, SkyHub to customize homepage, agenda MyPlanner, automatic backup mode to avoid downtime.
- USB port to download HACCP data, programs and settings. Connectivity ready.
- Single sensor core temperature probe.
- Double-glass door with LED lights.
- Stainless steel construction throughout.
- Supplied with n.1 tray rack 2/1 GN, 63 mm pitch.
- Adjustable levelling feet.

Main Features

- High resolution full touch screen interface (translated in more than 30 languages) - color-blind friendly panel.
- Boilerless steaming function to add and retain moisture for high quality, consistent cooking results.
- Dry hot convection cycle (max 300 °C) ideal for low humidity cooking. Automatic moistener (11 settings) for boiler-less steam generation.
- EcoDelta cooking: cooking with food probe maintaining preset temperature difference between the core of the food and the cooking chamber.
- Programs mode: a maximum of 1000 recipes can be stored in the oven's memory, to recreate the exact same recipe at any time. The recipes can be group in 16 different categories to better organize the menu. 16-step cooking programs also available.
- MultiTimer function to manage up to 20 different cooking cycles at the same time, improving flexibility and ensuring excellent cooking results. Can be saved up to 200 MultiTimer programs.
- OptiFlow air distribution system to achieve maximum performance in cooking evenness and temperature control thanks to a special design of the cooking chamber combined with high precision variable speed fan and venting valve.
- Fan with 7 speed levels from 300 to 1500 RPM and reverse rotation for optimal evenness. Fan stops in less than 5 seconds when door is opened.
- Single sensor core temperature probe included.
- Pictures upload for full customization of cooking cycles.
- Automatic fast cool down and pre-heat function.
- Reduced power function for customized slow cooking cycles.
- SkyClean: Automatic and built-in self cleaning system. 5 automatic cycles (soft, medium, strong, extra strong, rinse-only) and green functions to save energy, water, detergent and rinse aid. Also programmable with delayed start.
- 3 different chemical options available: solid (phosphate-free), liquid (requires optional accessory), enzymatic.
- Plan-n-Save function organizes the cooking sequence of the chosen cycles optimizing the work in the kitchen from a time and energy efficiency point of view.
- Make-it-mine feature to allow full personalization or locking of the user interface.
- SkyHub lets the user group the favorite functions in the homepage for immediate access.
- MyPlanner works as an agenda where the user can plan the daily work and receive personalized alerts for each task.
- GreaseOut: predisposed for integrated grease drain and collection for safer operation (dedicated base as optional accessory).
- USB port to download HACCP data, share cooking programs and configurations. USB port also allows to plug-in sous-vide probe (optional accessory).

APPROVAL: _____

- Connectivity ready for real time access to connected appliances from remote and HACCP monitoring (requires optional accessory).
- Trainings and guidances supporting materials easily accessible by scanning QR-Code with any mobile device.
- Back-up mode with self-diagnosis is automatically activated if a failure occurs to avoid downtime.
- Automatic consumption visualization at the end of the cycle.
- [NOT TRANSLATED]
- [NOT TRANSLATED]

Construction

- Human centered design with 4-star certification for ergonomics and usability.
- Wing-shaped handle with ergonomic design and hands-free opening with the elbow, making managing trays simpler (Registered Design at EPO).
- Double thermo-glazed door with open frame construction, for cool outside door panel. Swing hinged easy-release inner glass on door for easy cleaning.
- Seamless hygienic internal chamber with all rounded corners for easy cleaning.
- 304 AISI stainless steel construction throughout.
- Front access to control board for easy service.
- IPX 5 spray water protection certification for easy cleaning.
- Integrated door shield to avoid steam and heat dispersion from the door, when the roll-in rack is not used.
- Supplied with n.1 trolley rack 2/1 GN, 63 mm pitch.

Included Accessories

- 1 of - NOT TRANSLATED - PNC 922757

Optional Accessories

- Water softener with cartridge STEAM 1200 PNC 920003
- Automatic water softener for ovens PNC 921305
- Resin sanitizer for water softener PNC 921306
- Pair of 1/1 GN AISI 304 grids PNC 922017
- Couple of grids for whole chicken 1/1GN (8 per grid) PNC 922036
- ONE 1/1GN AISI 304 GRID FOR AOS OVEN USA PNC 922062
- Pastry trolley for 20x2/1GN ovens and bcf, 80mm pitch (16 runners). Suitable for 600x400mm pastry trays in oven PNC 922069
- Side external spray unit (needs to be mounted outside and includes support for mounting to oven) PNC 922171
- Baking tray with 5 rows (baguette), perforated aluminium with silicon coating (400x600x38) PNC 922189
- Baking tray with 4 edges, perforated aluminium (400x600x20) PNC 922190
- Baking tray with 4 edges, aluminium (400x600x20) PNC 922191
- 2 frying baskets for ovens PNC 922239
- Pastry grid, 400x600mm, AISI 304 stainless steel PNC 922264

- Grid for whole chicken 1/1GN (8 per grid - 1,2kg each) PNC 922266
- USB probe for Sous-Vide cooking - available on Touchline ovens with software versions after 4.10 PNC 922281
- Universal skewer rack PNC 922326
- 6 short skewers PNC 922328
- Smoker for lengthwise and crosswise ovens - 4 kinds of smoker wood chips are available on request PNC 922338
- Water filter for ovens - 4 membranes PNC 922344
- External reverse osmosis filter for ovens - 4 membranes PNC 922345
- Multipurpose hook PNC 922348
- GREASE COLLECTION TRAY WITH DRAIN LOCK - GN 2/1 H=60MM PNC 922357
- GRID FOR 8 WHOLE DUCKS (1.8KG) - GN 1/1 PNC 922362
- THERMAL COVER FOR 20 GN 2/1 OVEN PNC 922367
- HOLDER FOR DETERGENT TANK - WALL MOUNTED PNC 922386
- EXTERNAL CONNECTION KIT FOR DETERGENT/RINSE AID PNC 922618
- DEHYDRATION TRAY - GN 1/1 H=20MM PNC 922651
- DEHYDRATION TRAY - GN 1/1 FLAT PNC 922652
- HEAT SHIELD FOR 20 GN 2/1 OVEN PNC 922658
- KIT TO CONVERT FROM NATURAL GAS TO LPG PNC 922670
- KIT TO CONVERT FROM LPG TO NATURAL GAS PNC 922671
- FLUE CONDENSER FOR GAS OVENS PNC 922678
- TROLLEY TRAY RACK 15 GN 2/1 - 84MM PITCH PNC 922686
- KIT TO FIX OVEN TO THE WALL PNC 922687
- WIFI BOARD (NIU) PNC 922695
- MESH GRILLING GRID PNC 922713
- PROBE HOLDER FOR LIQUIDS PNC 922714
- TRAY FOR TRADITIONAL STATIC COOKING - H=100MM PNC 922746
- DOUBLE-FACE GRIDDLE (RIBBED AND SMOOTH) FOR OVENS - 400X600MM PNC 922747
- - NOT TRANSLATED - PNC 922757
- - NOT TRANSLATED - PNC 922758
- - NOT TRANSLATED - PNC 922760
- - NOT TRANSLATED - PNC 922762
- - NOT TRANSLATED - PNC 922764
- - NOT TRANSLATED - PNC 922770
- - NOT TRANSLATED - PNC 922771
- - NOT TRANSLATED - PNC 922773
- Non-stick universal pan 1/1GN H=40mm PNC 925001
- Non-stick universal pan 1/1GN H=60mm PNC 925002
- Frying griddle GN 1/1 for ovens PNC 925003
- Aluminium oven grill GN 1/1 PNC 925004
- FRYING PAN FOR 8 EGGS, PANCAKES, HAMBURGERS - GN 1/1 PNC 925005
- FLAT BAKING TRAY WITH 2 EDGES - GN 1/1 PNC 925006
- Potato baker GN 1/1 for 28 potatoes PNC 925008

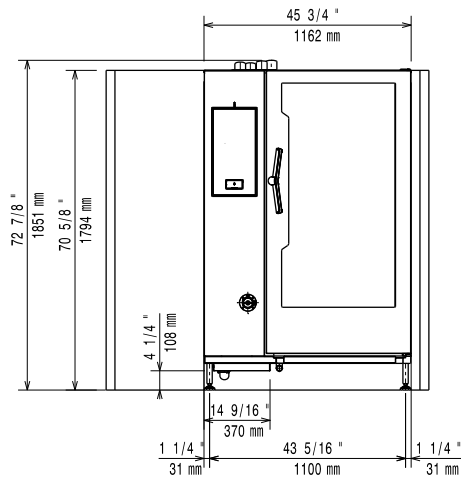
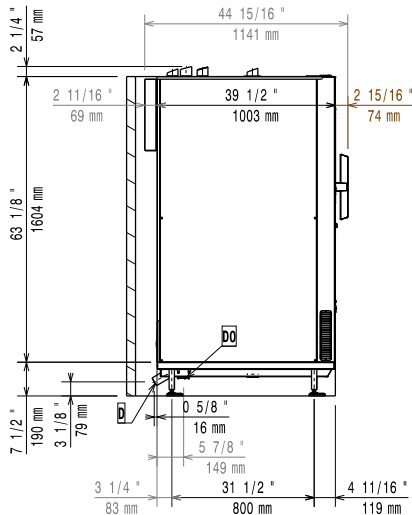
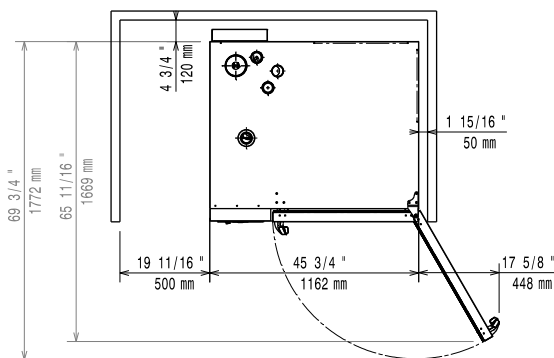
Front

Side

Top

- | | |
|---------------------------|-------------------------------|
| CW11 = Cold Water inlet 1 | EI = Electrical inlet (power) |
| CW12 = Cold Water Inlet 2 | G = Gas connection |
| D = Drain | |
| DO = Overflow drain pipe | |

Electric

Supply voltage:	
227665 (ECO E202K2U0)	230-240 V/1 ph/50 Hz
Electrical power, default:	2.5 kW
Electrical power max.:	2.5 kW
Circuit breaker required	

Gas

Gas Power:	76 kW
Standard gas delivery:	Natural Gas G20
ISO 7/1 gas connection diameter:	1" MNPT
LPG:	
Total thermal load:	281490 BTU (76 kW)

Water:

Water inlet "FCW" connection:	3/4"
Pressure, bar min/max:	1-4.5 bar
Drain "D":	50mm
Max inlet water supply temperature:	30 °C
Hardness	5 °fH / 2.8 °dH
Chlorides:	<10 ppm
Conductivity:	0 µS/cm
Electrolux recommends the use of treated water, based on testing of specific water conditions.	
Please refer to user manual for detailed water quality information.	

Installation:

Clearance:	Clearance: 5 cm rear and right hand sides.
Suggested clearance for service access:	50 cm left hand side.

Capacity:

GN:	20 - 2/1 Gastronorm
Max load capacity:	200 kg

Key Information:

Door hinges:	Right Side
External dimensions, Width:	1162 mm
External dimensions, Height:	1794 mm
External dimensions, Depth:	1066 mm
Weight:	450 kg
Net weight:	450 kg
Shipping weight:	475 kg
Shipping volume:	2.77 m ³