

SkyLine PremiumS Natural Gas Combi Oven 20GN1/1, Green Version

ITEM # _____

MODEL # _____

NAME # _____

SIS # _____

AIA # _____

229784 (ECOG20IT3U0)

SkyLine PremiumS combi boiler oven with touch screen control, 20x1/1GN, gas, 3 cooking modes (automatic, recipe program, manual), automatic cleaning, Green Version with 3-glass door

Short Form Specification

Item No. _____

Combi oven with high resolution full touch screen interface, multilanguage

- Built-in steam generator with real humidity control based upon Lambda Sensor
- OptiFlow air distribution system to achieve maximum performance with 7 fan speed levels
- SkyClean: Automatic and built-in self cleaning system with integrated descale of the steam generator. 5 automatic cycles (soft, medium, strong, extra strong, rinse-only) and green functions to save energy, water, detergent and rinse aid
- Cooking modes: Automatic (9 food families with 100+ different pre-installed variants); Programs (a maximum of 1000 recipes can be stored and organized in 16 different categories); Manual (steam, combi and convection cycles); Specialistic Cycles (regeneration, Low Temperature Cooking, proving, EcoDelta, Sous-Vide, Static-Combi, Pasteurization of pasta, dehydration, Food Safe Control and Advanced Food Safe Control)
- Special functions: MultiTimer cooking, Plan-n-Save to cut running costs, Make-it-Mine to customize interface, SkyHub to customize homepage, agenda MyPlanner, SkyDuo connection to SkyLine ChillerS, automatic backup mode to avoid downtime
- USB port to download HACCP data, programs and settings. Connectivity ready
- 6-point multi sensor core temperature probe
- Triple-glass door with double LED lights line
- Stainless steel construction throughout
- Supplied with n.1 trolley rack 1/1 GN, 63 mm pitch.
- Adjustable levelling feet.

Main Features

- [NOT TRANSLATED]
- [NOT TRANSLATED]
- High resolution full touch screen interface (translated in more than 30 languages) - color-blind friendly panel.
- Built-in steam generator for highly precise humidity and temperature control according to the chosen settings.
- Real humidity control based upon Lambda Sensor to automatically recognize quantity and size of food for consistent quality results.
- Dry, hot convection cycle (25 °C - 300 °C): ideal for low humidity cooking.
- Combination cycle (25 °C - 300 °C): combining convected heat and steam to obtain humidity controlled cooking environment, accelerating the cooking process and reducing weight loss.
- Low temperature Steam cycle (25 °C - 99 °C): ideal for sous-vide, re-thermalization and delicate cooking. Steam cycle (100 °C): seafood and vegetables. High temperature steam (25 °C - 130 °C).
- Automatic mode including 9 food families (meat, poultry, fish, vegetables, pasta/rice, eggs, savory and sweet bakery, bread, dessert) with 100+ different pre-installed variants. Through Automatic Sensing Phase the oven optimizes the cooking process according to size, quantity and type of food loaded to achieve the selected cooking result. Real time overview of the cooking parameters. Possibility to personalize and save up to 70 variants per family.
- Cycles+: - Regeneration (ideal for banqueting on plate or rethermalizing on tray), - Low Temperature Cooking (to minimize weight loss and maximize food quality) Patented US7750272B2 and related family, - Proving cycle, - EcoDelta cooking, cooking with food probe maintaining preset temperature difference between the core of the food and the cooking chamber, - Sous-vide cooking, - Static Combi (to reproduce traditional cooking from static oven), - Pasteurization of pasta, - Dehydration cycles (ideal for drying fruits, vegetables, meats, seafood), - Food Safe Control (to automatically monitor safety of cooking process in compliance with HACCP hygienic standards) Patented US6818865B2 and related family, - Advanced Food Safe Control (to drive the cooking with pasteurization factor).
- Programs mode: a maximum of 1000 recipes can be stored in the oven's memory, to recreate the exact same recipe at any time. The recipes can be group in 16 different categories to better organize the menu. 16-step cooking programs also available.
- MultiTimer function to manage up to 20 different cooking cycles at the same time, improving flexibility and ensuring excellent cooking results. Can be saved up to 200 MultiTimer programs.
- OptiFlow air distribution system to achieve maximum performance in cooking evenness and temperature control thanks to a special design of the cooking chamber combined with high

APPROVAL: _____

precision variable speed fan and venting valve.

- Fan with 7 speed levels from 300 to 1500 RPM and reverse rotation for optimal evenness. Fan stops in less than 5 seconds when door is opened.
- 6-point multi sensor core temperature probe for maximum precision and food safety.
- Pictures upload for full customization of cooking cycles.
- Automatic fast cool down and pre-heat function.
- Reduced power function for customized slow cooking cycles.
- SkyClean: Automatic and built-in self cleaning system with integrated descale of the steam generator. 5 automatic cycles (soft, medium, strong, extra strong, rinse-only) and green functions to save energy, water, detergent and rinse aid. Also programmable with delayed start.
- 3 different chemical options available: solid (phosphate-free), liquid (requires optional accessory), enzymatic.
- Plan-n-Save function organizes the cooking sequence of the chosen cycles optimizing the work in the kitchen from a time and energy efficiency point of view.
- Make-it-mine feature to allow full personalization or locking of the user interface.
- SkyHub lets the user group the favorite functions in the homepage for immediate access.
- MyPlanner works as an agenda where the user can plan the daily work and receive personalized alerts for each task.
- With SkyDuo the Oven and the Blast Chiller are connected to each other and communicate in order to guide the user through the cook&chill process optimizing time and efficiency (SkyDuo Kit available as optional accessory).
- GreaseOut: predisposed for integrated grease drain and collection for safer operation (dedicated base as optional accessory).
- USB port to download HACCP data, share cooking programs and configurations. USB port also allows to plug-in sous-vide probe (optional accessory).
- Connectivity ready for real time access to connected appliances from remote and HACCP monitoring (requires optional accessory).
- Trainings and guidances supporting materials easily accessible by scanning QR-Code with any mobile device.
- Back-up mode with self-diagnosis is automatically activated if a failure occurs to avoid downtime.
- Automatic consumption visualization at the end of the cycle.

Construction

- Double thermo-glazed door with open frame construction, for cool outside door panel. Swing hinged easy-release inner glass on door for easy cleaning.
- Human centered design with 4-star certification for ergonomics and usability.
- Wing-shaped handle with ergonomic design and hands-free opening with the elbow, making managing trays simpler (Registered Design at EPO).
- Seamless hygienic internal chamber with all rounded corners for easy cleaning.
- 304 AISI stainless steel construction throughout.
- Front access to control board for easy service.
- Integrated spray gun with automatic retracting system for fast rinsing.
- Supplied with n.1 tray rack 1/IGN, 63 mm pitch.

- IPX 5 spray water protection certification for easy cleaning.
- Integrated door shield to avoid steam and heat dispersion from the door, when the roll-in rack is not used.

Included Accessories

- 1 of - NOT TRANSLATED - PNC 922753

Optional Accessories

- Water softener with cartridge STEAM 1200 PNC 920003
- Automatic water softener for ovens PNC 921305
- Resin sanitizer for water softener PNC 921306
- Pair of 1/1 GN AISI 304 grids PNC 922017
- Couple of grids for whole chicken 1/IGN (8 per grid) PNC 922036
- ONE 1/1GN AISI 304 GRID FOR AOS OVEN USA PNC 922062
- Grid for whole chicken 1/2GN (4 per grid - 1,2kg each) PNC 922086
- Side external spray unit (needs to be mounted outside and includes support for mounting to oven) PNC 922171
- Baking tray with 5 rows (baguette), perforated aluminium with silicon coating (400x600x38) PNC 922189
- Baking tray with 4 edges, perforated aluminium (400x600x20) PNC 922190
- Baking tray with 4 edges, aluminium (400x600x20) PNC 922191
- 2 frying baskets for ovens PNC 922239
- Pastry grid, 400x600mm, AISI 304 stainless steel PNC 922264
- Grid for whole chicken 1/IGN (8 per grid - 1,2kg each) PNC 922266
- USB probe for Sous-Vide cooking - available on Touchline ovens with software versions after 4.10 PNC 922281
- Fat collection tray 100 mm PNC 922321
- Kit universal skewer rack and 4 long skewers for lengthwise ovens PNC 922324
- Universal skewer rack PNC 922326
- 4 long skewers PNC 922327
- Smoker for lengthwise and crosswise ovens - 4 kinds of smoker wood chips are available on request PNC 922338
- Water filter for ovens - 4 membranes PNC 922344
- External reverse osmosis filter for ovens - 4 membranes PNC 922345
- Multipurpose hook PNC 922348
- GRID FOR 8 WHOLE DUCKS (1.8KG) - GN 1/1 PNC 922362
- THERMAL COVER FOR 20 GN 1/1 OVEN PNC 922365
- HOLDER FOR DETERGENT TANK - WALL MOUNTED PNC 922386
- EXTERNAL CONNECTION KIT FOR DETERGENT/RINSE AID PNC 922618
- DEHYDRATION TRAY - GN 1/1 H=20MM PNC 922651
- DEHYDRATION TRAY - GN 1/1 FLAT PNC 922652
- HEAT SHIELD FOR 20 GN 1/1 OVEN PNC 922659
- KIT TO CONVERT FROM NATURAL GAS TO LPG PNC 922670
- KIT TO CONVERT FROM LPG TO NATURAL GAS PNC 922671

- FLUE CONDENSER FOR GAS OVENS PNC 922678
- TROLLEY TRAY RACK 15 GN 1/1 - 84MM PNC 922683
PITCH
- KIT TO FIX OVEN TO THE WALL PNC 922687
- WIFI BOARD (NIU) PNC 922695
- MESH GRILLING GRID PNC 922713
- PROBE HOLDER FOR LIQUIDS PNC 922714
- EXHAUST HOOD WITH FAN FOR 20 GN PNC 922730
1/1 OVEN
- EXHAUST HOOD WITHOUT FAN FOR PNC 922735
20 GN 1/1 OVEN
- TRAY FOR TRADITIONAL STATIC PNC 922746
COOKING - H=100MM
- DOUBLE-FACE GRIDDLE (RIBBED AND PNC 922747
SMOOTH) FOR OVENS - 400X600MM
- - NOT TRANSLATED - PNC 922753
- - NOT TRANSLATED - PNC 922754
- - NOT TRANSLATED - PNC 922756
- - NOT TRANSLATED - PNC 922763
- - NOT TRANSLATED - PNC 922769
- - NOT TRANSLATED - PNC 922771
- - NOT TRANSLATED - PNC 922773
- Non-stick universal pan 1/1GN H=40mm PNC 925001
- Non-stick universal pan 1/1GN H=60mm PNC 925002
- Frying griddle GN 1/1 for ovens PNC 925003
- Aluminium oven grill GN 1/1 PNC 925004
- FRYING PAN FOR 8 EGGS, PANCAKES, PNC 925005
HAMBURGERS - GN 1/1
- FLAT BAKING TRAY WITH 2 EDGES - GN PNC 925006
1/1
- BAKING TRAY FOR 4 BAGUETTES - GN PNC 925007
1/1
- Potato baker GN 1/1 for 28 potatoes PNC 925008
- Non-stick universal pan GN 1/2, PNC 925009
H=20mm
- Non-stick universal pan GN 1/2, PNC 925010
H=40mm
- Non-stick universal pan GN 1/2, PNC 925011
H=60mm

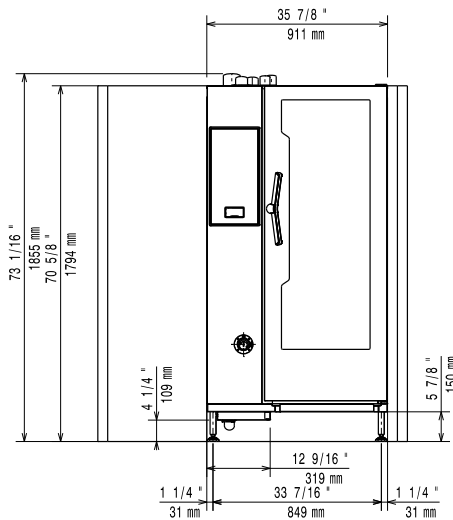
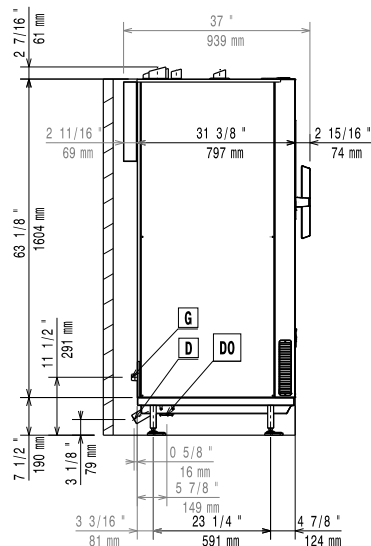
Front

Side

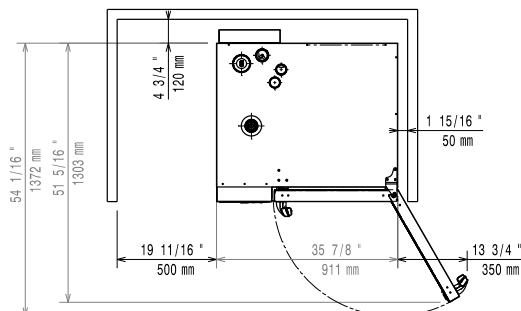
CWI1 = Cold Water inlet 1 EI = Electrical inlet (power)
 CWI2 = Cold Water Inlet 2 G = Gas connection
 D = Drain
 DO = Overflow drain pipe

Top

Electric

Supply voltage:
 229784 (ECO201T3U0) 230-240 V/1 ph/50 Hz
Electrical power, default: 1.8 kW
Electrical power max.: 1.8 kW
Circuit breaker required

Gas

Gas Power: 58.5 kW
Standard gas delivery: Natural Gas G20
ISO 7/1 gas connection diameter: 1" MNPT
LPG:
Total thermal load: 217344 BTU (58.5 kW)

Water:

Water inlet "FCW" connection: 3/4"
Pressure, bar min/max: 1-4.5 bar
Drain "D": 50mm
Max inlet water supply temperature: 30 °C
Chlorides: <17 ppm
Conductivity: >285 µS/cm
Electrolux recommends the use of treated water, based on testing of specific water conditions.
 Please refer to user manual for detailed water quality information.

Installation:

Clearance: Clearance: 5 cm rear and right hand sides.
Suggested clearance for service access: 50 cm left hand side.

Capacity:

GN: 20 - 1/1 Gastronorm
Max load capacity: 100 kg

Key Information:

Door hinges: Right Side
External dimensions, Width: 911 mm
External dimensions, Height: 1794 mm
External dimensions, Depth: 864 mm
Weight: 340 kg
Net weight: 340 kg
Shipping weight: 360 kg
Shipping volume: 1.83 m³