

## Modular Cooking Range Line 700XP 2 Drawer Refrigerated Base

ITEM # \_\_\_\_\_

MODEL # \_\_\_\_\_

NAME # \_\_\_\_\_

SIS # \_\_\_\_\_

AIA # \_\_\_\_\_

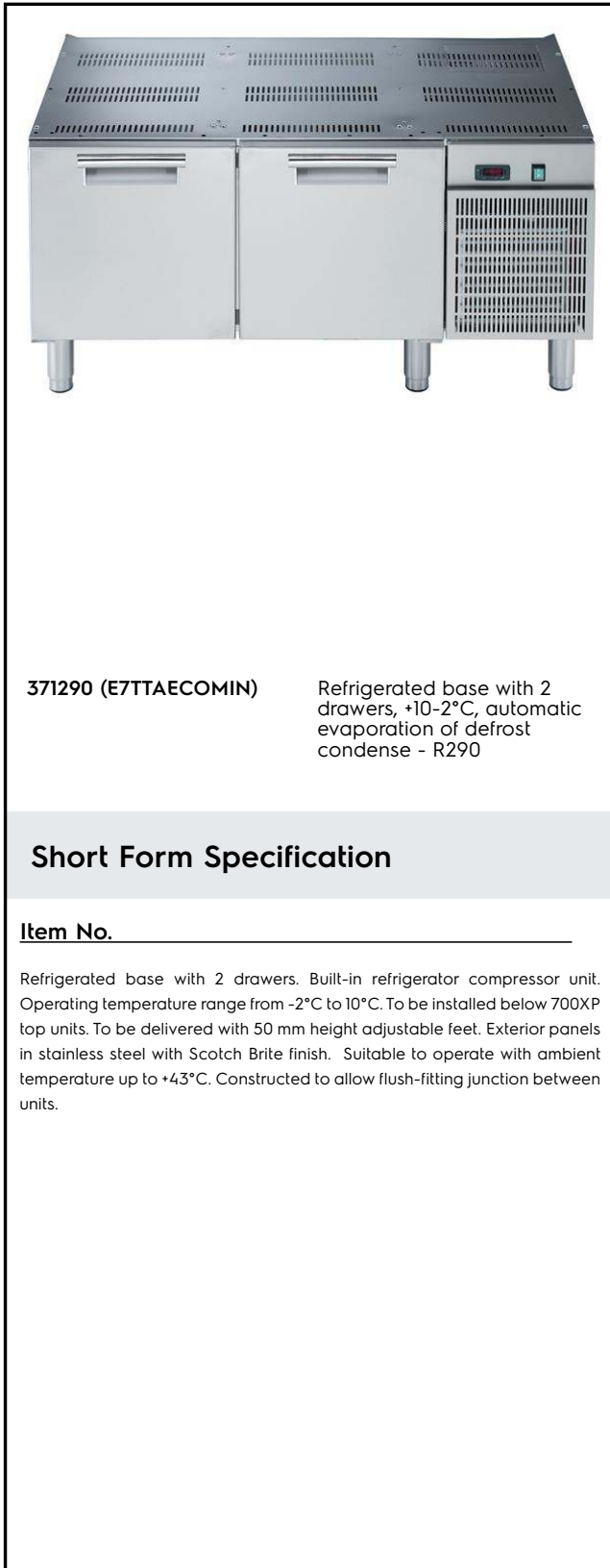
**371290 (E7TTAECOMIN)**

Refrigerated base with 2 drawers, +10-2°C, automatic evaporation of defrost condense - R290

### Short Form Specification

**Item No.** \_\_\_\_\_

Refrigerated base with 2 drawers. Built-in refrigerator compressor unit. Operating temperature range from -2°C to 10°C. To be installed below 700XP top units. To be delivered with 50 mm height adjustable feet. Exterior panels in stainless steel with Scotch Brite finish. Suitable to operate with ambient temperature up to +43°C. Constructed to allow flush-fitting junction between units.

**APPROVAL:** \_\_\_\_\_

### Main Features

- Defrosting and automatic evaporation of condense drain: the condense is automatically evaporated thanks to the electric resistance in the condense drain container.
- CFC and HCFC free (highly ecological refrigerant type: R290).
- GN compliant.
- Designed for modular installation into the cooking block.
- Unit can be easily installed below other 700 line top models.
- Unit delivered with 50 mm height adjustable feet in Stainless steel.
- Adjustable temperature range from -2 °C to +10 °C to suit meat, fish and dairy storage requirements.
- Forced air circulation for rapid cooling and an even temperature distribution.
- Right angled side edges eliminate gaps and possible dirt traps between units.

### Construction

- Exterior panels in Stainless steel with Scotch Brite finish to meet the highest hygiene standards.
- Built-in compressor to suit operating conditions.
- Access to all components from the front.

### Optional Accessories

- Flanged feet kit PNC 206136
- Frontal kicking strip for concrete installation, 1200mm PNC 206151
- Frontal kicking strip for concrete installation, 1600mm PNC 206152
- Frontal kicking strip, 1200mm (not for refr-freezer base) PNC 206178
- Frontal kicking strip, 1600mm (not for refr-freezer base) PNC 206179
- Kit 4 feet for concrete installation (not for 900 line free standing grill) PNC 206210
- 2 panels for service duct for single "top on base" installation PNC 206248
- Pair of side kicking strips PNC 206249
- Pair of side kicking strips for concrete installation PNC 206265
- 2 drawers for refrigerated base PNC 206351
- Base support for feet or wheels - 1200mm (700/900) PNC 206368
- Base support for feet or wheels - 1600mm (700/900) PNC 206369
- Rear paneling - 1200mm (700/900) PNC 206376

- Kit 6 wheels - 3 swivelling with brake PNC 206432
- 2 side covering panels for free PNC 216000  
standing appliances

Front

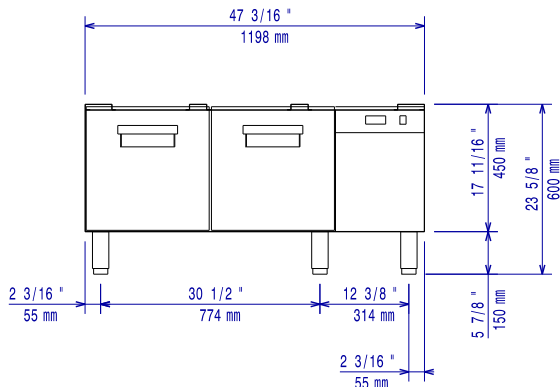

Side

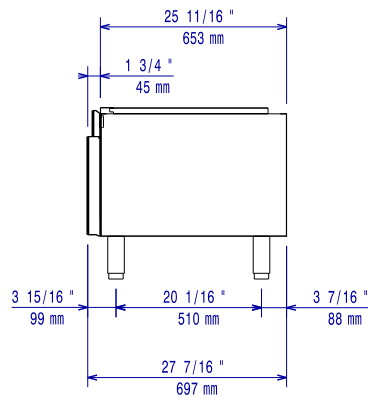

D = Drain  
 EI = Electrical inlet (power)

Top

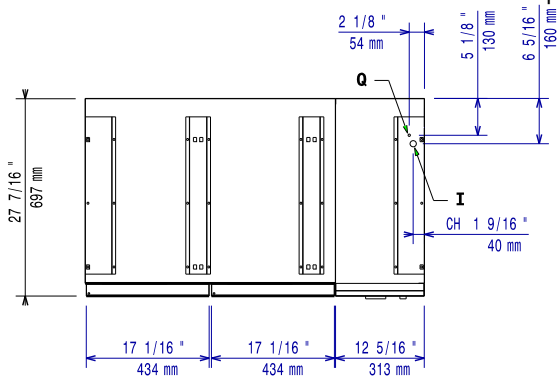

## Electric

Supply voltage:	371290 (E7TTAECOMIN)	220-230 V/1N ph/50 Hz
Electrical power max.:		0.4 kW
Total Watts:		0.4 kW

## Key Information:

Gross capacity:	152 lt
External dimensions, Width:	1200 mm
External dimensions, Height:	600 mm
External dimensions, Depth:	700 mm
Net weight:	95 kg
Shipping weight:	104 kg
Shipping height:	780 mm
Shipping width:	850 mm
Shipping depth:	1300 mm
Shipping volume:	0.86 m <sup>3</sup>

## Refrigeration Data

Refrigerant type:	R290
Refrigerant weight:	85 g