



Electrolux
PROFESSIONAL

Modular Cooking Range Line 700XP Gas Solid Top

ITEM # _____

MODEL # _____

NAME # _____

SIS # _____

AIA # _____

Electrolux
PROFESSIONAL

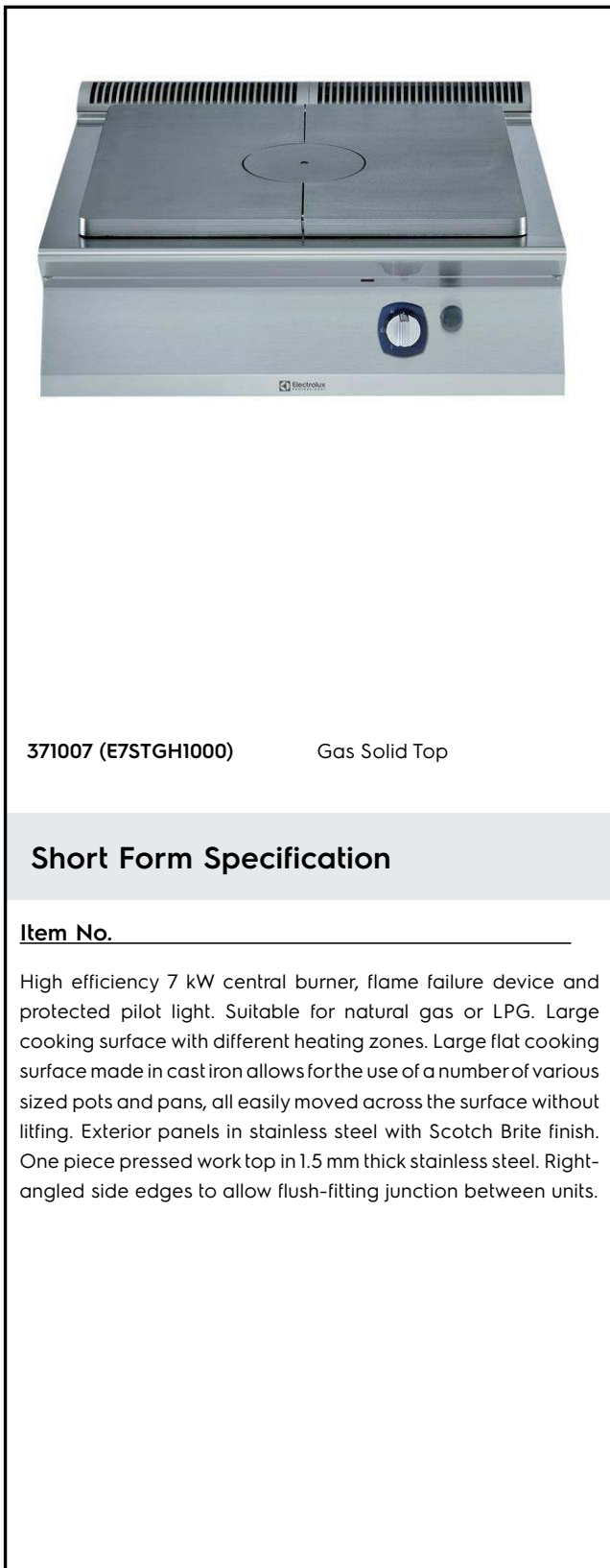

371007 (E7STGH1000)

Gas Solid Top

Short Form Specification

Item No. _____

High efficiency 7 kW central burner, flame failure device and protected pilot light. Suitable for natural gas or LPG. Large cooking surface with different heating zones. Large flat cooking surface made in cast iron allows for the use of a number of various sized pots and pans, all easily moved across the surface without lifting. Exterior panels in stainless steel with Scotch Brite finish. One piece pressed work top in 1.5 mm thick stainless steel. Right-angled side edges to allow flush-fitting junction between units.

Main Features

- Gas heated, 7 kW central burner, solid top.
- Durable cast iron cooking plate, easy to clean.
- The center of the plate can reach a maximum temperature of 500 °C while decreasing outwards.
- Central burner with optimized combustion, flame failure device and protected pilot light.
- Temperature gradients to satisfy different cooking needs, provided over the whole plate thanks to the temperature fine-tuning by zone.
- Various sizes of pans can be used at the same time due to large surface area with no intermediate sectors.
- Pans can easily be moved from one area to another without lifting.
- All major compartments located in front of unit for ease of maintenance.

Construction

- All exterior panels in Stainless Steel with Scotch Brite finishing.
- One piece pressed 1.5 mm work top in Stainless steel.
- Model has right-angled side edges to allow flush fitting joints between units, eliminating gaps and possible dirt traps.
- IPx4 water protection.

Optional Accessories

- Junction sealing kit PNC 206086
- Matching ring for flue condenser, 150 mm diameter PNC 206133
- Support for bridge type installation, 800mm PNC 206137
- Support for bridge type installation, 1000mm PNC 206138
- Support for bridge type installation, 1200mm PNC 206139
- Support for bridge type installation, 1400mm PNC 206140
- Support for bridge type installation, 1600mm PNC 206141
- Flue condenser for 1 module, 150 mm diameter PNC 206246
- Water column with swivel arm (water column extension not included) PNC 206289
- Water column extension for 700 line PNC 206291
- Chimney upstand, 800mm PNC 206304
- Right and left side handrails PNC 206307
- Wok pan support for open burners (700/900) PNC 206363

APPROVAL: _____



Experience the Excellence
www.electroluxprofessional.com

Modular Cooking Range Line
700XP Gas Solid Top

- Kit town gas nozzles (G150) for 700 solid top and burner PNC 206388
- Chimney grid net, 400mm (700XP/900) PNC 206400
- Frontal handrail, 800mm PNC 216047
- Frontal handrail, 1200mm PNC 216049
- Frontal handrail, 1600mm PNC 216050
- Large handrail - portioning shelf, 800mm PNC 216186
- 2 side covering panels for top appliances PNC 216277
- Pressure regulator for gas units PNC 927225

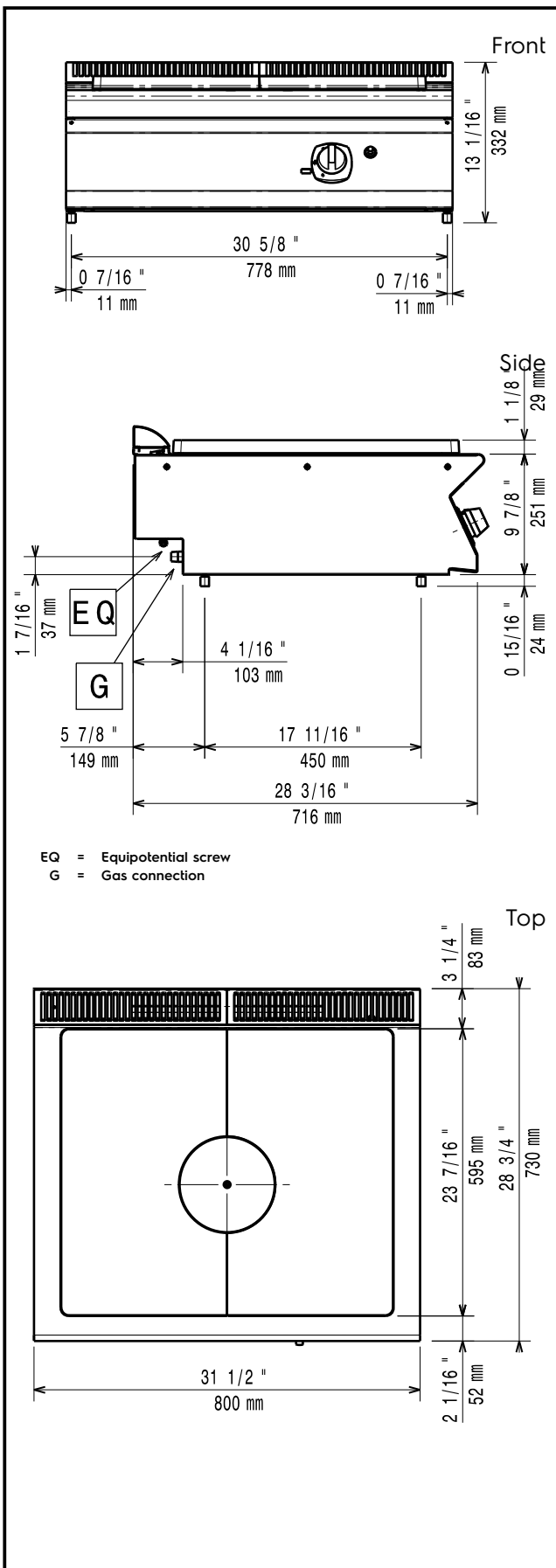

Gas

Gas Power:	
371007 (E7STGH1000)	7 kW
Standard gas delivery:	Natural Gas G20 (20mbar)
Gas Type Option:	LPG
Gas Inlet:	1/2"

Key Information:

Solid top usable surface (width):	690 mm
Solid top usable surface (depth):	595 mm
External dimensions, Width:	800 mm
External dimensions, Height:	250 mm
External dimensions, Depth:	730 mm
Net weight:	65 kg
Shipping weight:	66 kg
Shipping height:	520 mm
Shipping width:	820 mm
Shipping depth:	860 mm
Shipping volume:	0.37 m ³

If appliance is set up or next to or against temperature sensitive furniture or similar, a safety gap of approximately 150 mm should be maintained or some form of heat insulation fitted.

Certification group: N7TG