

EM Series 6 Open Gas Burner Range with Static Oven 36"

ITEM # _____

MODEL # _____

NAME # _____

SIS # _____

AIA # _____

169166 (ACFG36TW)

6-burner gas range (with thermocouples) on gas static oven 36" - AUS

Short Form Specification

Item No. _____

Unit to be Electrolux Six (6) Open Gas Burner Range with Static Oven. Individually controlled high efficiency 32,500 BTU (9.5 kW) Flower Flame burners. Control knobs provide smooth, continuous rotation from min to max. Suitable for natural gas or propane gas. Cast iron pan supports 12" x 12" (305 mm x 305 mm). Full width crumb tray below the burners. All major components can be accessed from the top and front of the appliance for ease of maintenance. Worktop in AISI 304 Stainless Steel. Front and side panels in Stainless Steel with Scotch Brite finish. Special heavy duty chrome plated knobs for durability and easy cleaning. The configuration of bezels and knobs provides high level of protection against water infiltrations. Right-angled side edges to allow flush fitting between units. Supplied with 6" (150 mm) height adjustable, removable legs. Unit may be installed on castors. 24" (610 mm) static oven 34,000 BTU/hr (10 kW) with unique baffle above the burner distributes heat to provide even cooking temperatures throughout the cavity. Vitreous enamelled oven interior accommodates two standard Imperial full size 18" x 26" (457 mm x 660 mm) sheet pans. The interior is 19-1/2" w x 26-3/4" d x 15" h (497 mm w x 680 mm d x 380 mm h). 100% safety pilot. Manual oven shut-off valve. Heavy duty thermostat with temperature range from 158°F to 590°F (70°C to 310°C). Oven supplied with two stainless steel tray racks.

Main Features

- Six individually controlled high efficiency 9.5 kW Flower Flame gas burners.
- Control knobs provide smooth, continuous rotation from min to max power level.
- No gaskets and removable one-piece venturis and burners for easy cleaning.
- The geometrics of the venturis and cast iron burners provides the maximum level of heating efficiency.
- The cast iron burners are anti-clogging.
- The cast iron pan supports 305 mm x 305 mm, thanks to the special configuration, allow for even small pots and pans to be placed over the flame.
- The cast iron pan supports allow to slide pots and pans from section to section as well as to protect the pilot from spilled food and debris.
- Full width crumb tray below the burners captures all overflow and debris and can be easily extracted for dumping and cleaning.
- All major components can be accessed from the top and front of the appliance for ease of maintenance.
- 24" (610 mm) static oven 34,000 BTU/hr (10 kW) with unique baffle above the burner distributes heat to provide even cooking temperatures throughout the cavity.
- Vitreous enamelled oven interior accommodates two standard Imperial full size 18" x 26" (457 mm x 660 mm) sheet pans.
- The interior is 497 mm w x 680 mm d x 380 mm h.
- 100% safety pilot.
- Manual oven shut-off valve.
- Heavy duty thermostat with temperature range from 70 °C to 310 °C.
- Oven supplied with two stainless steel tray racks.
- Front and side panels in Stainless Steel with Scotch Brite finish.
- Special heavy duty chrome plated knobs for durability and easy cleaning.
- The configuration of bezels and knobs provides high level of protection against water infiltrations.
- Right-angled side edges to allow flush fitting joints between units, eliminating gaps and possible dirt traps.
- Provided with kit for side-by-side connection between units for minimizing gaps and possible dirt traps.
- Supplied with 150 mm height adjustable, removable legs.
- Unit may be installed on castors.
- Included accessories: propane converter kit, pressure regulator and main shut off valve.
- Height adjustable feet.
- Unit with thermocouple and flame failure device protects against accidental extinguishing of the flame.

Construction

- Worktop in 304 AISI stainless steel.

APPROVAL: _____

- Gas pressure regulator is supplied with the unit.

Optional Accessories

- EM Series Restaurant Range kit shelf support 36" PNC 169080
- BACKSHELF TO WALL INSTALL.36 "UNITS PNC 169099
- PORTIONING SHELF 12" PNC 169173
- PORTIONING SHELF 16" PNC 169174
- PORTIONING SHELF 24" PNC 169175
- PORTIONING SHELF 36" PNC 169176
- Kit 4 wheels - 2 swivelling with brake - it is mandatory to install base support and wheels PNC 206135

Front

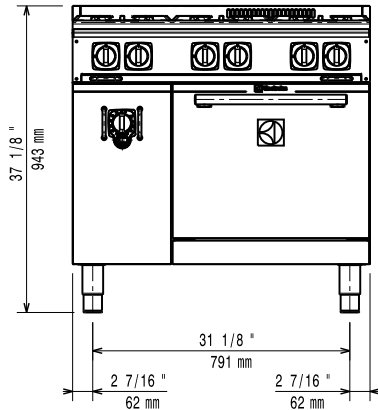

Side

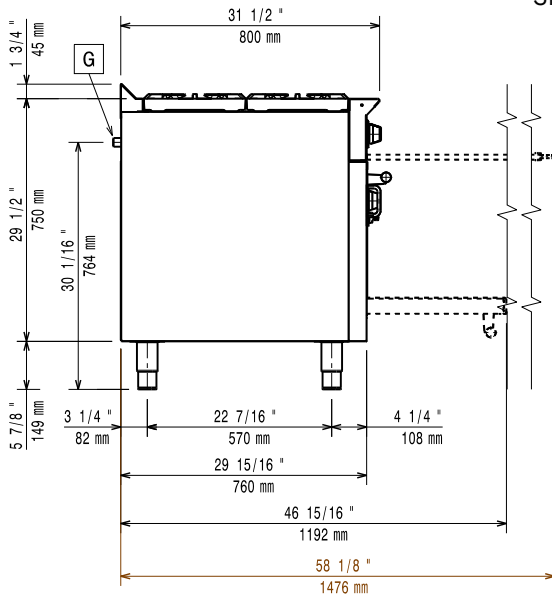

G = Gas connection

Top

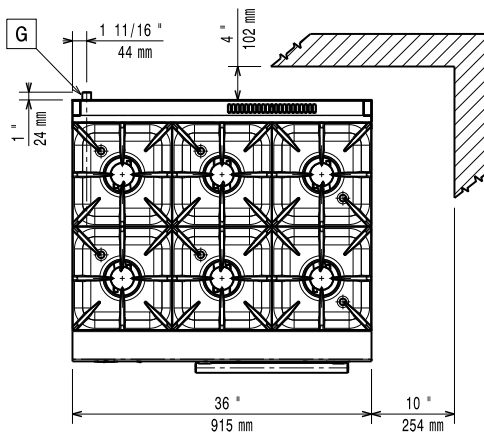
Gas

Gas Power:	169166 (ACFG36TW)	229000 Btu/hr (67 kW)
Gas Inlet:		1/2"
Natural gas - Pressure:		3" w.c. (7 mbar)
Propane Gas Pressure:		7" w.c. (17.4 mbar)

Key Information:

Oven working Temperature:	158 °F (70 °C) MIN - 590 °F (310 °C) MAX
Oven Cavity Dimensions (width):	19 9/16" (497 mm)
Oven Cavity Dimensions (depth):	26 3/4" (680 mm)
Oven Cavity Dimensions (height):	14 15/16" (380 mm)
External dimensions, Width:	36 1/32" (915 mm)
External dimensions, Depth:	31 1/2" (800 mm)
External dimensions, Height:	37 3/16" (945 mm)
Net weight:	355 lbs (161 kg)
Shipping width:	40 9/16" (920 mm)
Shipping depth:	37 1/64" (980 mm)
Shipping height:	46 7/16" (1190 mm)
Shipping weight:	481 lbs (193 kg)
Shipping volume:	40.34 ft ³ (1.07 m ³)

*The rear and side clearances shown on the diagram indicate the minimum distances recommended from the appliance to combustible surfaces.