

MHC16-10

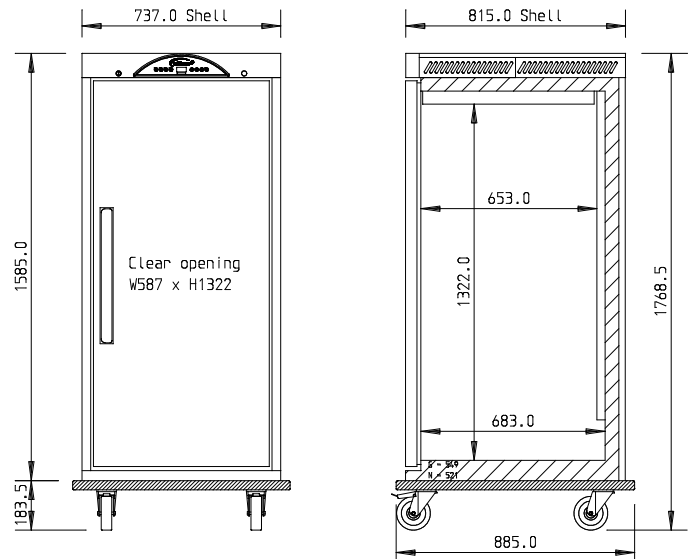

CATEGORY	FOODSERVICE SPECIALISED
RANGE	Mobile Banquet Cart
UNIT	HEATED MOBILE CABINET
TYPE	SELF CONTAINED
DOORS	1

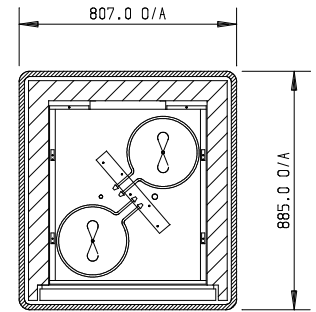

SPECIFICATIONS

CAPACITY - 2/1 50MM DEEP GN PANS	16 tray slides
TEMPERATURE	78°C / 82°C
DIMENSIONS - W X D X H (ON CASTORS) MM	807 W x 885 D x 1768 H
WEIGHT UNPACKED (KG)	150

STANDARD INCLUSIONS ***

DOOR TYPE	Standard: SD (Solid Door)
FINISH (INTERIOR AND EXTERIOR)	SS (Stainless Steel)
TRAY SLIDES	16

ELECTRICAL

POWER SUPPLY	10 amp
POWER CABLE LENGTH (METRES)	2
RUNNING AMPS	9.0

*** For **OPTIONS** refer to the current Williams Price Guide