

# MAR1-HC

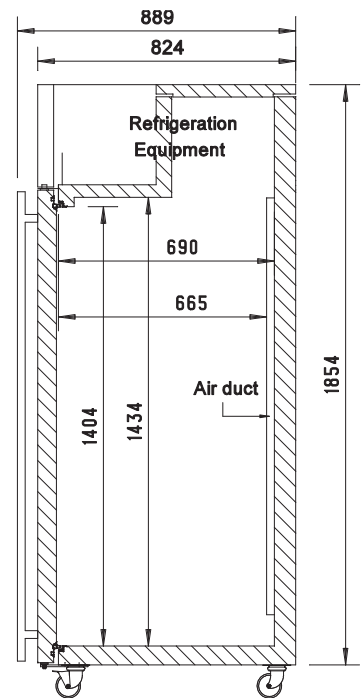

|          |                                 |
|----------|---------------------------------|
| CATEGORY | HYDROCARBON                     |
| RANGE    | <b>Meat ageing refrigerator</b> |
| UNIT     | DRY AGE REFRIGERATOR            |
| TYPE     | SELF CONTAINED                  |
| DOORS    | 1                               |

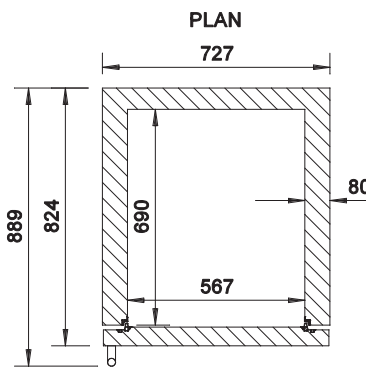
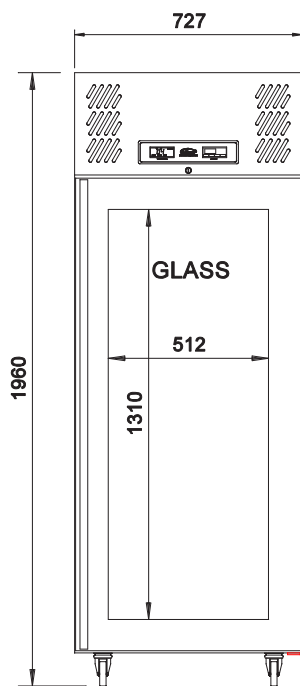

## SPECIFICATIONS

|  |                        |
|--|------------------------|
| CAPACITY LITRES                        | 620                    |
| TEMPERATURE                            | 1°C / 6°C              |
| DIMENSIONS - W X D X H (ON CASTORS) MM | 727 W x 889 D x 1960 H |
| WEIGHT UNPACKED (KG)                   | 230                    |

## STANDARD INCLUSIONS

|   |                           |
|---|---------------------------|
| DOOR TYPE   | Standard: GD (Glass Door) |
| FINISH (INTERIOR AND EXTERIOR EXCLUDING REAR AND UNDER) | SS (Stainless Steel)      |
| SHELVES/DOOR  | 4                         |

## ELECTRICAL

|                             |        |
|-----------------------------|--------|
| POWER SUPPLY                | 10 amp |
| POWER CABLE LENGTH (METRES) | 2      |
| RUNNING AMPS                | 1.65   |

## GAS TYPE

|             |      |
|-------------|------|
| REFRIGERANT | R290 |
|-------------|------|