

Technical Specifications for WV-1A

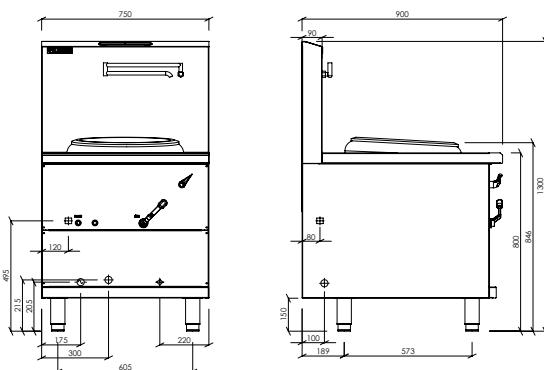

ASIAN

- Inspired by the fast-paced kitchens of Hong Kong
- 'Fo San' is Cantonese for *volcano* representing the raw heat and power generated by the unique burner set-up
- Refined 11th generation Luus *superwork* design
- Fan-forced burner generates greater output compared to some standard wok burners on the market
- Intense heat and focused flame targets the wok centre and provides unmatched stir frying speeds
- Luus' unique burner & pilot set up is the most effective design on the market at preventing grease/water blockages
- Compact 900mm space saving overall unit depth
- Natural cooling via insulation and rear flue design
- Entirely redesigned electrical system with faster ignition, auto re-ignition and greater reliability.
- 24 month 'Platinum Warranty'



Model	Description	Nat Gas	LP Gas
WV-1A	1 air-blast burner wok	145 mj	145 mj

Fo San Wok

- 145 mj Air-Blast Burner with 3 mj pilot & FFD standard
- Electronic auto-ignition switch and burner reset function
- Fan-forced stainless steel burner easy-to-clean design
- External pilot position most effective at avoiding blockages
- Fire-brick lined combustion chamber and ceramic base
- Rear flue system provides effective & efficient combustion
- Quarter turn water control lever
- Folding rear laundry arm with front panel controls
- Front gutter design for easier cleaning
- Internal front heat shield panel
- Supplied with waste strainer
- Zinc-aluminium Alloy burner handles
- Ergonomically designed burner handle can be repositioned at 45° orientations to match personal preference

Overall Construction

- Heavy duty construction
- Robust, full skirt, 355mm cast-iron ring
- 1.5mm 304 stainless steel top deck
- Splashback 1.2 mm 304 stainless steel
- Front cover and hob 1.2mm 304 stainless steel
- Side panels 0.9mm 304 stainless steel
- Stainless steel removable legs
- 55mm height adjustment range
- 1.5mm 304 stainless steel base panel
- One-piece hob and deck

Dimensions

- 750mm x 900mm x 1300mm H
- Working height 800mm
- Weight 155kg
- Packed dimensions 800mm x 950mm x 1470mm H
- Packed weight 180kg

Connections

- 3/4" BSP Male
- Gas 300mm from left, 100mm from rear, 215mm to floor
- Gas regulator built-in to gas train
- Water inlet 1/2" tube with check valve
- Water 220mm from left 60mm to rear, 205mm to floor
- Drain 2" pipe
- Drain 120mm from left 80mm from rear, 495mm to floor
- Electrical input rated at 220-240V, 10A, 50Hz & 150W
- Electrical input located 175mm from left, 205mm from floor
- Length of cable from rear is 600mm

Cleaning & Servicing

- Front gutter design and waste strainer for easier cleaning
- Top surface and skirting is easy to clean from above
- Burner removable and accessible from above
- Burner injector, electrode and flame probe accessible
- Control box accessible via lower front cover
- Drain and tap accessible by removing upper front cover
- Gas train, air-line, fan and burner accessible by removing front covers

Options/Accessories

- Lowered splashback to 1100mm overall height
- 250mm wide clip on shelves (front)
- Joining caps & strips
- RH and LH side shields
- Rear castors