

## Snackmaster Small Conveyor Oven W.CVS.SE.20



### Product Information:

- 305mm belt width conveyor oven, ideal for toasting/cooking open snacks
- Ideal for toasting/cooking open snacks and a variety of other foods
- Long life metal elements for continuous use
- 300mm long cooking conveyor for easy loading
- Touchpad “set and forget” control system
- Fan cooled controls and fan forced heat technology
- Fully insulated top and body retains heat inside where it should be
- Energy efficient pulse power independent temperature controls for top and bottom elements
- Variable speed belt control with automatic tensioning
- Stainless steel construction
- W.CVS.SE.20 supplied with 2 metre lead and 20 Amp single phase 3 round pin capture plug for fitting on site to a suitable industrial style outlet, connected to a 4mm<sup>2</sup> cable
- Units configured for right to left conveyor operation as standard. Left to right operation is available upon request and can be selected at time of order by adding an “L” to end of the model number
- Optional stacking kit available

### Specifications:

|                   |                         |
|-------------------|-------------------------|
| <b>Model</b>      | <b>W.CVS.SE.20</b>      |
| <b>Height</b>     | 465mm                   |
| <b>Width</b>      | 1000mm                  |
| <b>Depth</b>      | 445mm                   |
| <b>Belt Width</b> | 305mm                   |
| <b>Power</b>      | 4.8kW<br>20A 1Ø + N + E |

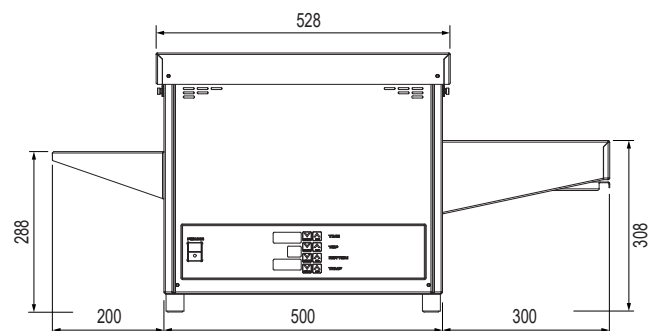
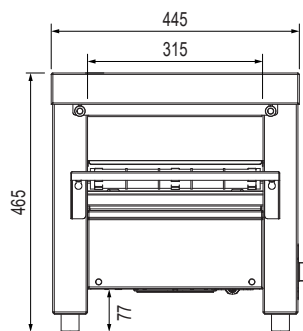
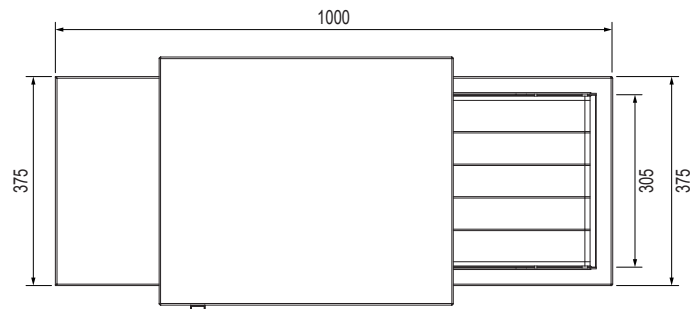

Due to continuous product research and development, the information contained herein is subject to change without notice.

Revision: E - 25/05/2022 - 01

[www.stoddart.com.au](http://www.stoddart.com.au)

[www.stoddart.co.nz](http://www.stoddart.co.nz)