



**Steam
BOX**
EVOLUTION

ESSENCE OF EVOLUTION COMBI OVENS

Specifications

Model	SEHG201WT
W x D x H (mm)	998 x 925 x 1888
Weight	300kg
Capacity	20 X 1/1GN
Gas (Natural / Universal LPG)	3/4 BSP, 136.8MJ/Hr
Power	3.3 kW 230V 15A plug & lead fitted
Waste Connection	50mm
Cold Water Connection	3/4 BSP 150-350 kpa Min 10°C Max 35°C

Water Quality Requirements

Hardness	60-100ppm
TDS	<100mg/L
Cl Chloride	<32mg/L

Legend

A	Electrical connection
B	Gas inlet (3/4" BSP)
C	Steam generation water inlet (3/4" BSP)
D	Wash system water inlet (3/4" BSP)
E	Drain connection
F	Humidity vent
G	Gas emission exhaust
H	Detergent and rinse aid inlet

Due to continuous product research and development, the information contained herein is subject to change without notice.

SEHG201WT

Premium Gas Combi Oven
20 x 1/1GN - 20 Tray

Product Information:

- Natural or Universal LPG Gas available (advise required gas type when ordering)
- **Symbiotic Steam (patented)** innovative, heavy duty, highly efficient, dual boiler generation and steam injection oven
- **Steam Tuner (patented)** exclusive feature allows actual tuning of saturated steam
- **Meteo System (patented)** for precise control and saturation levels
- Automatic descaling system for oven and boiler
- Integrated recirculating cleaning via tablet, with liquid detergent dispenser installed if preferred
- Large 9" innovative touch screen interface, with Wi-Fi as standard
- Over 120 pre-set cooking programs, 1,000+ additional programs - 9 phase memory available
- Automatic, adaptive cooking, rack control, regeneration, sous vide and smoking programs
- Easy Service function, Recipe tuner, and Chef's note software all as standard
- 6-speed inverter controlled fan for increased precision, control and reliability
- LED lighting for superior cavity illumination
- Integrated hand shower, USB connection and multi-point core probe
- Wi-Fi enabled for live service monitoring and assistance through live Giorik/Stoddart Cloud
- Left hand hinge door option available, this variation is 30mm wider and is made to order
- **48-month warranty** (Terms and conditions apply)

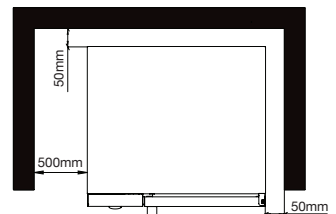
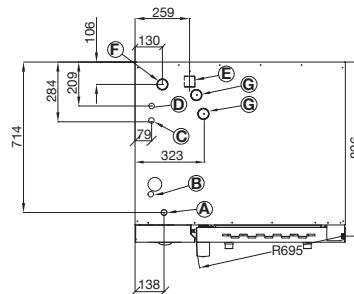
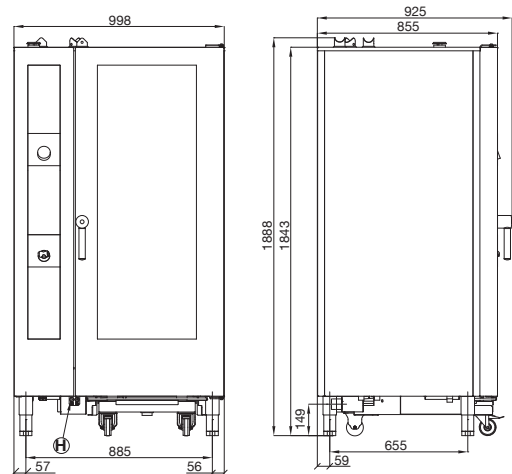

*Clearance requirements
*Drain line must be vented

* **Heat Source:** 500mm clearance from an external heat source is required in order to protect the oven control components and allow access to the service panel. For clearances under 500mm, it is mandatory for Stoddart heat shields to be fitted while still maintaining a minimum clearance of 300mm to provide access to the service compartment. Failure to adhere to minimum clearances may void the oven warranty or add service costs due to lack of access.

Non-Heat Source: Generally 300mm clearance is required from the control panel side to allow access to the service panel. Any distance under 300mm, may add service costs due to lack of access.