

KT0623TW

Kompatto Oven

6 x 2/3GN Tray Electric Model

Product Code:

KT = Kompatto Instant Steam
 0623 = 6 x 2/3GN Tray model

Technical Data:

Dimensions: 519 x 628 x 770
 (W x D x H)
 Total Connected Load: 4.7kW
 Electrical Connection: 3Ø + N + E
 Water: 3/4" cold water supply
 minimum 2.5 bar

Optional Accessories:

Stand with Runners
 Stacking Kits
 Riser stand
 Reverse Osmosis System
 Right Hand Door Hinge Door
 Smoker
 Sous Vide Probe

Product Information:

- High efficiency instant steam oven, for quality steam generation
- Space saving solution, as footprint is only 519mm from left to right
- Meteo system (patented) for precise humidity control improves cooking quality
- Steam tuner (patented) for tuning dry-wet steam
- Touch screen control board with 9 phase programming up to 500 programs
- 100 pre-set cooking programs
- Multi level cooking, low temperature cooking, Delta T and regeneration possibilities
- Heating of cooking chamber with high performance incaloy heating elements
- 6 adjustable fan speeds, with automatic cooldown
- USB port for uploading and saving recipes, HACCP logging and firmware updating
- Double glazed easy opening door along with simple non-latching shutting
- Multi-rail system allows cooking flexibility by having double selections for loading

Includes:

- Wash system
- Hand shower
- Core temperature probe
- Advanced scale reduction filter (WA, NT & SA excluded as RO unit is required)
- Drain kit

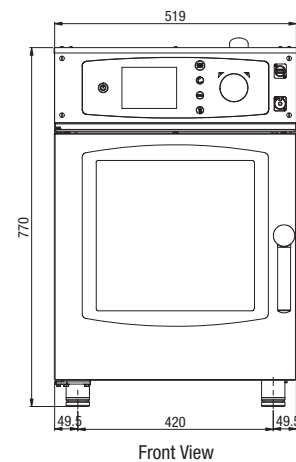
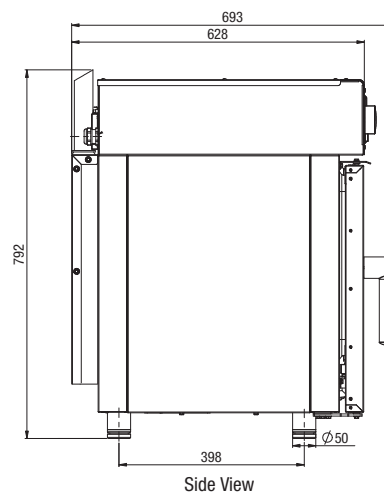
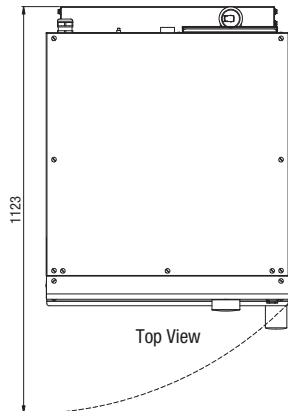

Due to continuous product research and development, the information contained herein is subject to change without notice

Manufactured By:

Tom Stoddart Pty Ltd. ABN 16 009690251
 39 Forest Way, Karawatha 4117 Queensland Australia
 Tel : +61 7 3440 7600 Fax : +61 7 33441000
 Web site: www.stoddart.com.au