



Electrolux

EMPower 6 Open Gas Burner Top 36"

ITEM # _____

MODEL # _____

NAME # _____

SIS # _____

AIA # _____



Electrolux



EMPower

6 Open Gas Burner Top 36"

169132 (ACG36T)

EMPower Restaurant Range burners, gas, 36" wide, (6) 32,500 BTU open burners with (4" adjustable, removable legs)

Short Form Specification

Item No. _____

Unit to be Electrolux Six (6) Open Gas Burner Top. Individually controlled high efficiency 9.5 kW Flower Flame burners. Control knobs provide smooth, continuous rotation from min to max. Suitable for natural gas or propane gas. Cast iron pan supports 305 mm x 305 mm. Full width crumb tray below the burners. All major components can be accessed from the top and front of the appliance for ease of maintenance. Worktop in AISI 304 Stainless Steel. Front and side panels in Stainless Steel with Scotch Brite finish. Special heavy duty chrome plated knobs for durability and easy cleaning. The configuration of bezels and knobs provides high level of protection against water infiltrations. Right-angled side edges to allow flush fitting between units. Supplied with 102 mm height adjustable, removable legs. Unit may be installed on refrigerated base or open cupboard.

Main Features

- Six individually controlled high efficiency 9.5 kW Flower Flame gas burners.
- Control knobs provide smooth, continuous rotation from min to max power level.
- No gaskets and removable one-piece venturis and burners for easy cleaning.
- The geometrics of the venturis and cast iron burners provides the maximum level of heating efficiency.
- The cast iron burners are anti-clogging.
- The cast iron pan supports 305 mm x 305 mm, thanks to the special configuration, allow for even small pots and pans to be placed over the flame.
- The cast iron pan supports allow to slide pots and pans from section to section as well as to protect the pilot from spilled food and debris.
- Full width crumb tray below the burners captures all overflow and debris and can be easily extracted for dumping and cleaning.
- Unit with thermocouple and flame failure device protects against accidental extinguishing of the flame (dedicated model).
- All major components can be accessed from the top and front of the appliance for ease of maintenance.
- Front and side panels in Stainless Steel with Scotch Brite finish.
- Special heavy duty chrome plated knobs for durability and easy cleaning.
- The configuration of bezels and knobs provides high level of protection against water infiltrations.
- Right-angled side edges to allow flush fitting joints between units, eliminating gaps and possible dirt traps.
- Provided with kit for side-by-side connection between units for minimizing gaps and possible dirt traps.
- Supplied with 102 mm height adjustable, removable legs.
- Unit may be installed on refrigerated base by removing the legs and inserting the special pins (optional accessory).
- Unit may be installed on open cupboard by removing the legs and inserting the screws provided as standard with the open cupboards.
- Included Accessories: propane converter kit, pressure regulator and main shut off valve.
- In compliance with ETL Certification (UL & NSF).

Construction

- Worktop in 304 AISI stainless steel.

Optional Accessories

- 4 pins to fix top to refrigerated/ open base PNC 169048
- EM Series Restaurant Range kit shelf support 36" PNC 169080
- BACKSHELF TO WALL INSTALL.36"UNITS PNC 169099

APPROVAL: _____

- PORTIONING SHELF 12" PNC 169173
- PORTIONING SHELF 16" PNC 169174
- PORTIONING SHELF 24" PNC 169175
- PORTIONING SHELF 36" PNC 169176

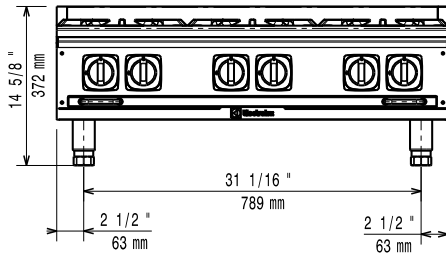
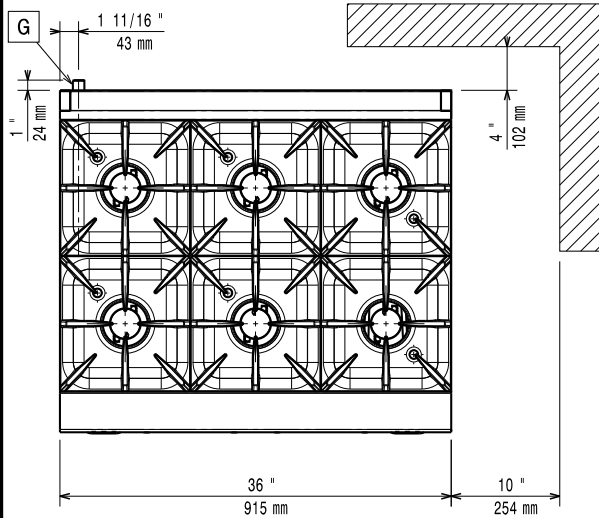

Front

Top

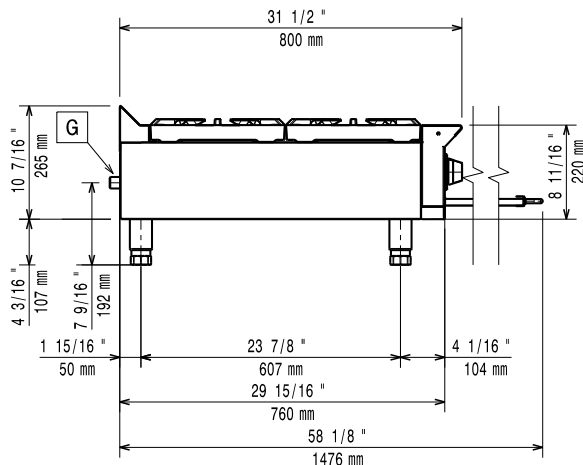
EQ = Equipotential screw
G = Gas connection

Side

Gas

Gas Power:
169132 (ACG36T) 195000 Btu/hr (57 kW)
Gas Inlet: 1/2"

Key Information:

External dimensions, Width: 36 1/32" (915 mm)
External dimensions, Depth: 31 1/2" (800 mm)
External dimensions, Height: 14 5/8" (372 mm)
Net weight: 185 lbs (84 kg)
Shipping width: 38 9/16" (979 mm)
Shipping depth: 36 1/16" (916 mm)
Shipping height: 27 1/16" (688 mm)
Shipping weight: 209 lbs (95 kg)
Shipping volume: 21.79 ft³ (0.62 m³)

*The rear and side clearances shown on the diagram indicate the minimum distances recommended from the appliance to combustible surfaces.