



Electrolux

Modular Cooking Range Line 900XP Half Module Gas Fry Top, Non-thermostatic

ITEM # _____

MODEL # _____

NAME # _____

SIS # _____

AIA # _____



Modular Cooking Range Line

900XP Half Module Gas Fry Top, Non-thermostatic

- | | |
|----------------------------|---|
| 391056 (E9FTGDSS0C) | Half module gas fry top with smooth sloped mild steel plate |
| 391057 (E9FTGDSR0C) | Half module gas fry top with ribbed sloped mild steel plate |

Short Form Specification

Item No. _____

Unit to be Electrolux 900XP Half Module Gas Fry Top. Unit to have ___smooth or ___ribbed cooking surface. Cooking surface to be of mild steel. Unit to have 8 kW gas powered burners with gas cock and piezo igniter. Unit to be installed on open base installations, bridging supports or cantilever systems. Unit to feature a collector on bottom the cooking surface for the collection of grease and fat. Body and work top of unit entirely in Stainless steel with Scotch Brite finish. Extra strength work top in heavy duty 2 mm Stainless steel. Unit has right-angled side edges to allow flush-fitting junction between units.

APPROVAL: _____

Main Features

- Unit to be mounted on open base cupboards, bridging supports or cantilever systems.
- Cooking surface in 15mm thick mild steel for optimum grilling results.
- Large drain hole on cooking surface permits the draining of fat into large 1,5 liter collector placed under the cooking surface.
- High-precision gas cock control with pilot flame and piezo ignition for added safety.
- Welded splash guards in stainless steel on the rear and sides of cooking surface.
- Cooking surface easy to remove for maintenance (operated by authorized technician).
- The special design of the control knob system guarantees against water infiltration.
- IPX5 water protection.

Construction

- Cooking surface to be completely smooth or completely ribbed.
- Unit is 930 mm deep to give a larger working surface area.
- All exterior panels in Stainless Steel with Scotch Brite finishing.
- AISI 304 stainless steel worktop, 2mm thick.
- Model has right-angled side edges to allow flush fitting joints between units, eliminating gaps and possible dirt traps.

Optional Accessories

- Scraper for smooth plate fry tops PNC 164255
- Junction sealing kit PNC 206086
- Draught diverter, 120 mm diameter PNC 206126
- Matching ring for flue condenser, 120 mm diameter PNC 206127
- Support for bridge type installation, 800mm PNC 206137
- Support for bridge type installation, 1000mm PNC 206138
- Support for bridge type installation, 1200mm PNC 206139
- Support for bridge type installation, 1400mm PNC 206140
- Support for bridge type installation, 1600mm PNC 206141
- Water drain for half module fry tops PNC 206153
- Support for bridge type installation, 400mm PNC 206154



Electrolux

Modular Cooking Range Line
900XP Half Module Gas Fry Top, Non-thermostatic

- Water column with swivel arm (water column extension not included) PNC 206289
- Water column extension for 900 line PNC 206290
- Chimney upstand, 400mm PNC 206303
- Flue condenser for 1/2 module, 120 mm diameter PNC 206310
- Grease/oil kit container for 700 line frytops (half and module) and 900 line frytops (module) PNC 206346
- Chimney grid net, 400mm (700XP/900) PNC 206400
- Scraper for ribbed plate fry tops - kit includes knife blades for both smooth and ribbed surface (only for 391057) PNC 206420
- Side handrail-right/left hand (900XP) PNC 216044
- Frontal handrail, 400mm PNC 216046
- Frontal handrail, 800mm PNC 216047
- Frontal handrail, 1200mm PNC 216049
- Frontal handrail, 1600mm PNC 216050
- Large handrail - portioning shelf, 400mm PNC 216185
- Large handrail - portioning shelf, 800mm PNC 216186
- 2 side covering panels for top appliances PNC 216278
- Pressure regulator for gas units PNC 927225

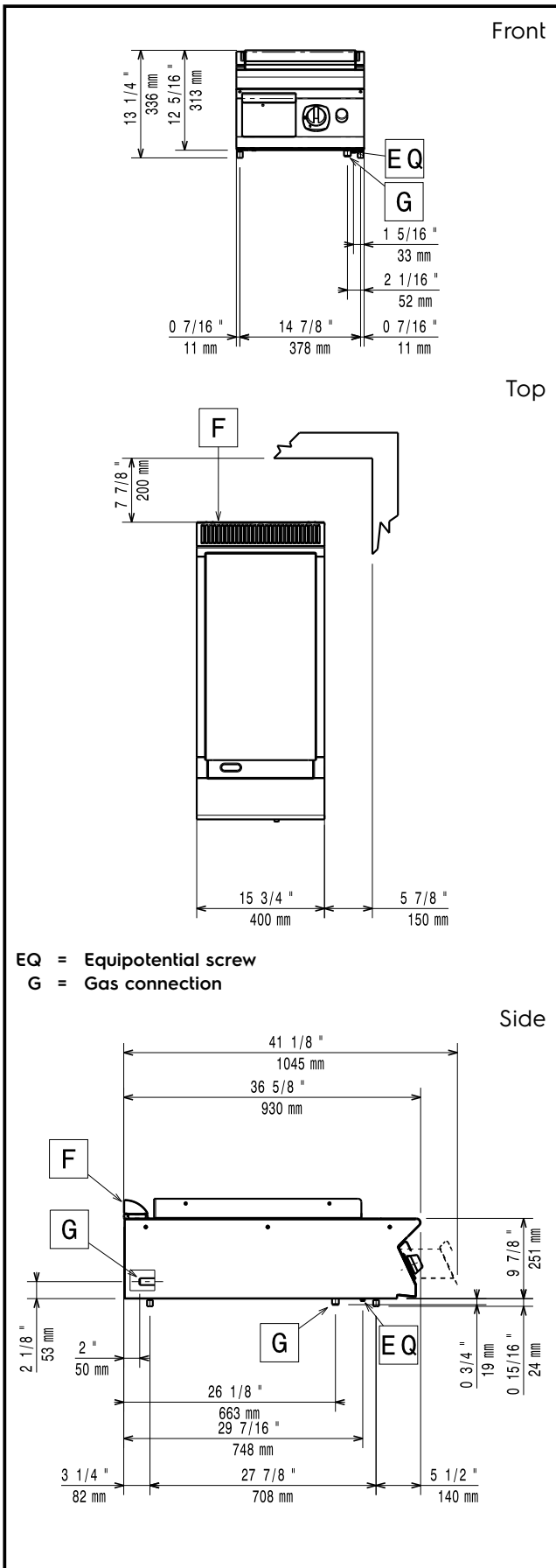

Gas

Gas Power:

391056 (E9FTGDSS0C) 27272 Btu/hr (8 kW)

391057 (E9FTGDSR0C) 27272 Btu/hr (8 kW)

Gas Type Option:

LPG; Natural Gas

Gas Inlet:

1/2"

Natural gas - Pressure:

391056 (E9FTGDSS0C) 7" w.c. (17.4 mbar)

LPG Gas Pressure:

391056 (E9FTGDSS0C) 11" w.c. (27.7 mbar)

Key Information:

Cooking surface width: 344 mm

Cooking surface depth: 647 mm

Working Temperature MIN: 210 °C

Working Temperature MAX: 420 °C

Net weight: 52 kg

Shipping weight:

391056 (E9FTGDSS0C) 58 kg

391057 (E9FTGDSR0C) 62 kg

Shipping height:

391056 (E9FTGDSS0C) 510 mm

391057 (E9FTGDSR0C) 540 mm

Shipping width: 460 mm

Shipping depth: 1020 mm

Shipping volume:

391056 (E9FTGDSS0C) 0.26 m³

391057 (E9FTGDSR0C) 0.28 m³

If appliance is set up or next to or against temperature sensitive furniture or similar, a safety gap of approximately 150 mm should be maintained or some form of heat insulation fitted.