



Electrolux

Modular Cooking Range Line 900XP 2-Hot Plates Electric Boiling Top

ITEM # _____

MODEL # _____

NAME # _____

SIS # _____

AIA # _____



Modular Cooking Range Line 900XP 2-Hot Plates Electric Boiling Top

- | | |
|----------------------------|--|
| 391039 (E9ECED2Q00) | 2-hot square plates (4 kW each) electric boiling top |
| 391165 (E9ECED2Q0N) | 2-hot plate (4 kW each) electric boiling top |

Short Form Specification

Item No. _____

To be installed on open base installations, bridging supports or cantilever systems. Two 4 kW square cast-iron hot plates hermetically sealed to the one-piece top. Exterior panels of unit in stainless steel with Scotch Brite finish. Extra strength work top in heavy duty 2 mm stainless steel. Right-angled side edges to allow flush-fitting junction between units.

Main Features

- Unit to be mounted on open base cupboards, bridging supports or cantilever systems.
- The two 4kW cast-iron plates are hermtically sealed to the one-piece top. Hot plates with a power of 4kW for each plate.
- The special design of the control knob system guarantees against water infiltration.
- IPX5 water protection.

Construction

- Unit is 930 mm deep to give a larger working surface area.
- All exterior panels in Stainless Steel with Scotch Brite finishing.
- AISI 304 stainless steel worktop, 2mm thick.
- Model has right-angled side edges to allow flush fitting joints between units, eliminating gaps and possible dirt traps.

APPROVAL: _____



Electrolux

Modular Cooking Range Line
900XP 2-Hot Plates Electric Boiling Top

Optional Accessories

- Pair of cast iron plate bars for electric cooking top PNC 206056
- Junction sealing kit PNC 206086
- Kit 4 wheels - 2 swivelling with brake - it is mandatory to install base support and wheels PNC 206135
- Support for bridge type installation, 800mm PNC 206137
- Support for bridge type installation, 1000mm PNC 206138
- Support for bridge type installation, 1200mm PNC 206139
- Support for bridge type installation, 1400mm PNC 206140
- Support for bridge type installation, 1600mm PNC 206141
- Support for bridge type installation, 400mm PNC 206154
- Water column with swivel arm (water column extension not included) PNC 206289
- Water column extension for 900 line PNC 206290
- Chimney upstand, 400mm PNC 206303
- Base support for feet or wheels - 400mm (700/900) PNC 206366
- Chimney grid net, 400mm (700XP/900) PNC 206400
- Side handrail-right/left hand (900XP) PNC 216044
- Frontal handrail, 400mm PNC 216046
- Frontal handrail, 800mm PNC 216047
- Frontal handrail, 1200mm PNC 216049
- Frontal handrail, 1600mm PNC 216050
- Large handrail - portioning shelf, 400mm PNC 216185
- Large handrail - portioning shelf, 800mm PNC 216186
- 2 side covering panels for top appliances PNC 216278



Electrolux

Modular Cooking Range Line 900XP 2-Hot Plates Electric Boiling Top

Front

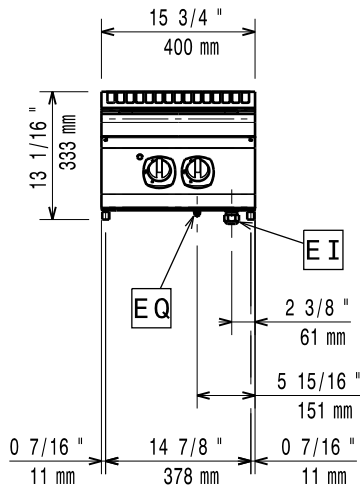

Top

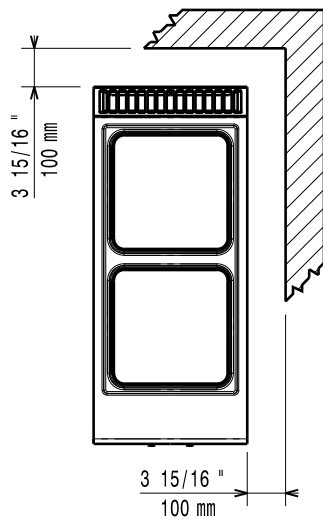

EI = Electrical connection
EQ = Equipotential screw

Side

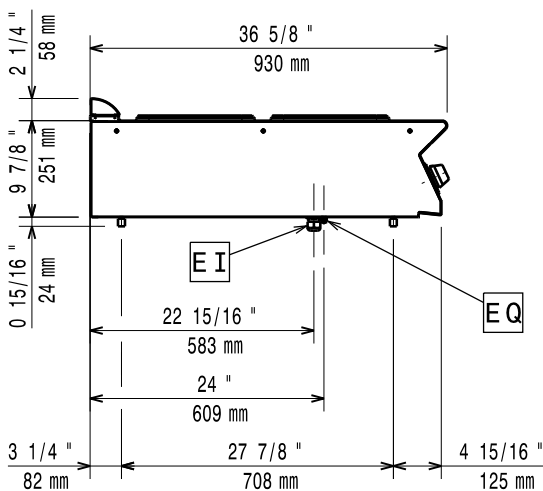

Electric

Supply voltage:

391039 (E9ECED2Q00)	400 V/3N ph/50/60 Hz
391165 (E9ECED2Q0N)	230 V/3 ph/50/60 Hz

Total Watts:

8 kW

Key Information:

Front Plates Power: 4 - 0 kW

Back Plates Power: 4 - kW

Front Plates dimensions: 300x300

Back Plates dimensions: 300x300

Net weight: 35 kg

Shipping weight:

391039 (E9ECED2Q00) 41 kg

391165 (E9ECED2Q0N) 45 kg

Shipping height: 540 mm

Shipping width: 460 mm

Shipping depth: 1020 mm

Shipping volume: 0.25 m³

If appliance is set up or next to or against temperature sensitive furniture or similar, a safety gap of approximately 150 mm should be maintained or some form of heat insulation fitted.



Modular Cooking Range Line
900XP 2-Hot Plates Electric Boiling Top

The company reserves the right to make modifications to the products without prior notice. All information correct at time of printing.