



# Electrolux

## Modular Cooking Range Line 900XP Gas Solid Top

ITEM # \_\_\_\_\_

MODEL # \_\_\_\_\_

NAME # \_\_\_\_\_

SIS # \_\_\_\_\_

AIA # \_\_\_\_\_



Electrolux

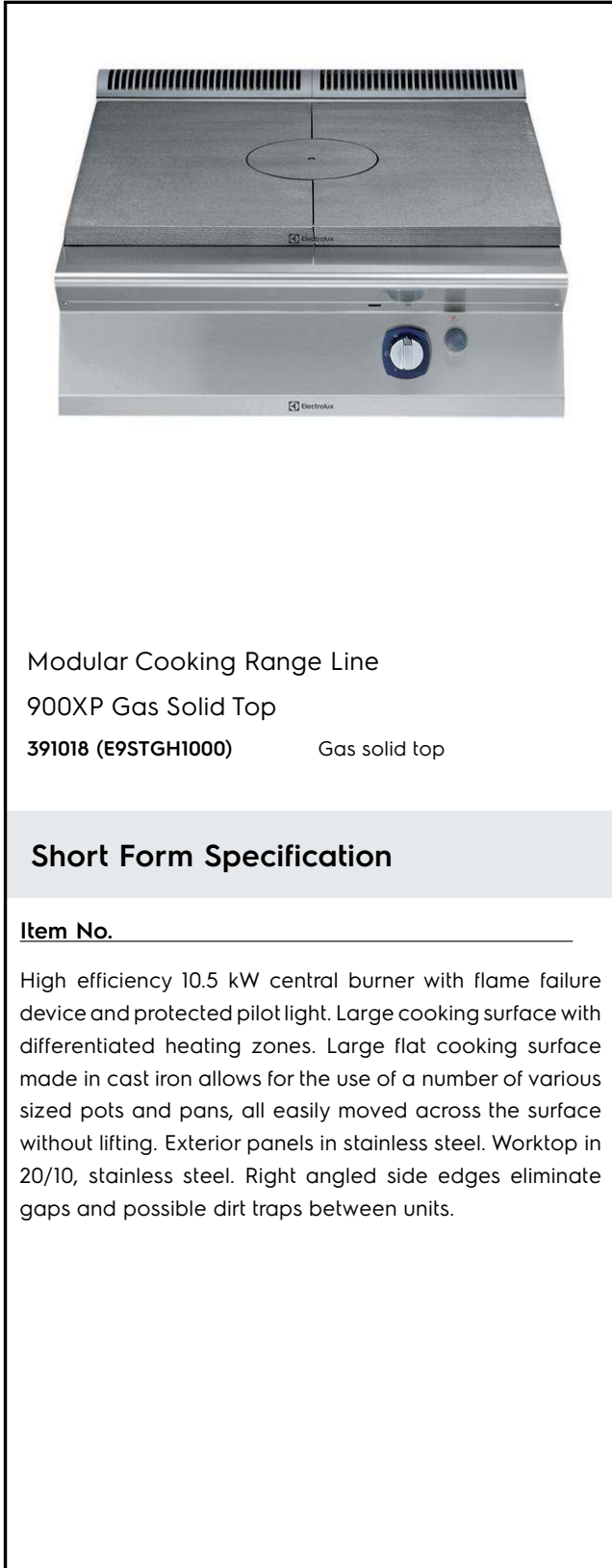

Modular Cooking Range Line

900XP Gas Solid Top

391018 (E9STGH1000) Gas solid top

### Short Form Specification

**Item No.** \_\_\_\_\_

High efficiency 10.5 kW central burner with flame failure device and protected pilot light. Large cooking surface with differentiated heating zones. Large flat cooking surface made in cast iron allows for the use of a number of various sized pots and pans, all easily moved across the surface without lifting. Exterior panels in stainless steel. Worktop in 20/10, stainless steel. Right angled side edges eliminate gaps and possible dirt traps between units.

### Main Features

- Gas heated, 10.5 kW central burner, solid top.
- Durable cast iron cooking plate, easy to clean.
- The center of the plate can reach a maximum temperature of 500 °C while decreasing outwards.
- Central burner with optimized combustion, flame failure device and protected pilot light.
- Piezo ignition.
- Temperature gradients to satisfy different cooking needs, provided over the whole plate thanks to the temperature fine-tuning by zone.
- Various sizes of pans can be used at the same time due to large surface area with no intermediate sectors.
- Pans can easily be moved from one area to another without lifting.
- All major compartments located in front of unit for ease of maintenance.
- IPX5 water resistance certification.
- The special design of the control knob system guarantees against water infiltration.

### Construction

- Unit is 930 mm deep to give a larger working surface area.
- All exterior panels in Stainless Steel with Scotch Brite finishing.
- Model has right-angled side edges to allow flush fitting joints between units, eliminating gaps and possible dirt traps.

### Optional Accessories

- Junction sealing kit PNC 206086
- Draught diverter, 150 mm diameter PNC 206132
- Matching ring for flue condenser, 150 mm diameter PNC 206133
- Kit 4 wheels - 2 swivelling with brake - it is mandatory to install base support and wheels PNC 206135
- Support for bridge type installation, 800mm PNC 206137
- Support for bridge type installation, 1000mm PNC 206138
- Support for bridge type installation, 1200mm PNC 206139
- Support for bridge type installation, 1400mm PNC 206140
- Support for bridge type installation, 1600mm PNC 206141
- Flue condenser for 1 module, 150 mm diameter PNC 206246

APPROVAL: \_\_\_\_\_

- Water column with swivel arm (water column extension not included)  PNC 206289
- Water column extension for 900 line  PNC 206290
- Chimney upstand, 800mm  PNC 206304
- Base support for feet or wheels - 800mm (700/900)  PNC 206367
- Kit town gas nozzles (G150) for 900 solid top with burners  PNC 206386
- Chimney grid net, 400mm (700XP/900)  PNC 206400
- Side handrail-right/left hand (900XP)  PNC 216044
- Frontal handrail, 800mm  PNC 216047
- Frontal handrail, 1200mm  PNC 216049
- Frontal handrail, 1600mm  PNC 216050
- Large handrail - portioning shelf, 400mm  PNC 216185
- Large handrail - portioning shelf, 800mm  PNC 216186
- 2 side covering panels for top appliances  PNC 216278
- Pressure regulator for gas units  PNC 927225

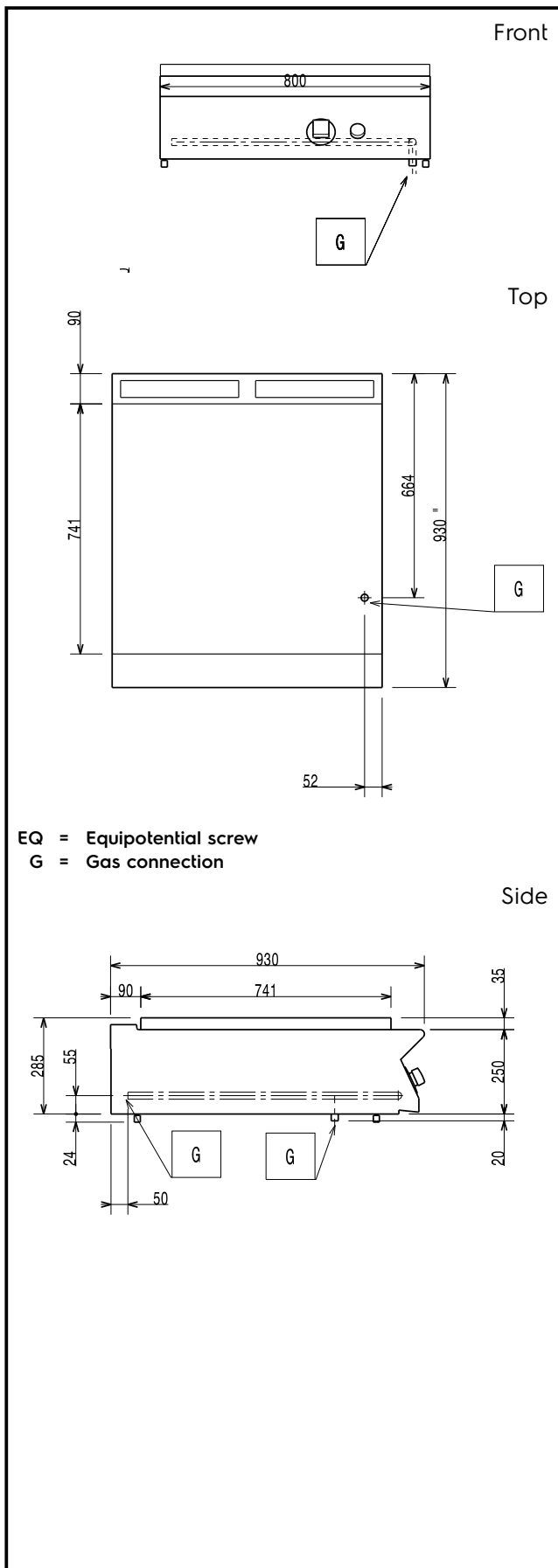

### Gas

<b>Gas Power:</b>	
391018 (E9STGH1000)	35794.5 Btu/hr (10.5 kW)
<b>Gas Type Option:</b>	LPG; Natural Gas
<b>Gas Inlet:</b>	1/2"
<b>Natural gas - Pressure:</b>	7" w.c. (17.4 mbar)
<b>LPG Gas Pressure:</b>	11" w.c. (27.7 mbar)

### Key Information:

<b>Solid top usable surface (width):</b>	800 mm
<b>Solid top usable surface (depth):</b>	700 mm
<b>Net weight:</b>	92 kg
<b>Shipping weight:</b>	115 kg
<b>Shipping height:</b>	540 mm
<b>Shipping width:</b>	1020 mm
<b>Shipping depth:</b>	860 mm
<b>Shipping volume:</b>	0.47 m <sup>3</sup>

If appliance is set up or next to or against temperature sensitive furniture or similar, a safety gap of approximately 150 mm should be maintained or some form of heat insulation fitted.