



Electrolux

Modular Cooking Range Line 700XP Half Module Electric Fry Top, Chromium Steel

ITEM # _____

MODEL # _____

NAME # _____

SIS # _____

AIA # _____



Modular Cooking Range Line

700XP Half Module Electric Fry Top, Chromium Steel

371193 (E7FTEDCS10)

Half module electric fry top with smooth chrome plate, thermostatic control

Short Form Specification

Item No. _____

To be installed on open base installations or bridging supports. Smooth cooking surface in chromium-plated mild steel. Temperature range from 110°C to 280°C. Removable drawer below the cooking surface for the collection of grease and fat. Exterior panels in stainless steel with Scotch Brite finish. One piece pressed work top in 1.5 mm thick stainless steel. Right-angled side edges to allow flush-fitting junction between units.

Main Features

- Unit to be mounted on open base cupboards, bridging supports or cantilever systems.
- Large drain hole on cooking surface permits the draining of fat into large 1 liter collector placed under the cooking surface.
- Large grease collection container available as optional accessory to be installed under top units over open base cupboard.
- Electric elements in incoloy positioned under the cooking plate.
- Safety thermostat and thermostatic control.
- Stainless steel high splash guard on the rear and sides of cooking surface. Splash guard can be easily removed for cleaning.
- Temperature range of griddle from 110 °C to 280 °C.
- IPX 4 water protection.

Construction

- Cooking surface in chromium-plated mild steel for optimum grilling results.
- All exterior panels in Stainless Steel with Scotch Brite finishing.
- One piece pressed 1.5 mm work top in Stainless steel.
- Model has right-angled side edges to allow flush fitting joints between units, eliminating gaps and possible dirt traps.
- Cooking surface to be completely smooth.

APPROVAL: _____



Electrolux

Modular Cooking Range Line
700XP Half Module Electric Fry Top, Chromium Steel

Optional Accessories

- Scraper for smooth plate fry tops PNC 164255
- Support for bridge type installation, 800mm PNC 206137
- Support for bridge type installation, 1000mm PNC 206138
- Support for bridge type installation, 1200mm PNC 206139
- Support for bridge type installation, 1400mm PNC 206140
- Support for bridge type installation, 1600mm PNC 206141
- Support for bridge type installation, 400mm PNC 206154
- Water column with swivel arm (water column extension not included) PNC 206289
- Water column extension for 700 line PNC 206291
- Chimney upstand, 400mm PNC 206303
- Right and left side handrails PNC 206307
- Grease/oil kit container for 700 line frytops (half and module) and 900 line frytops (module) PNC 206346
- Base support for feet or wheels - 400mm (700/900) PNC 206366
- Rear paneling - 600mm (700/900XP) PNC 206373
- Rear paneling - 800mm (700/900) PNC 206374
- Rear paneling - 1000mm (700/900) PNC 206375
- Rear paneling - 1200mm (700/900) PNC 206376
- Chimney grid net, 400mm (700XP/900) PNC 206400
- Frontal handrail, 400mm PNC 216046
- Frontal handrail, 800mm PNC 216047
- Frontal handrail, 1200mm PNC 216049
- Frontal handrail, 1600mm PNC 216050
- Large handrail - portioning shelf, 400mm PNC 216185
- Large handrail - portioning shelf, 800mm PNC 216186
- 2 side covering panels for top appliances PNC 216277



Electrolux

Modular Cooking Range Line 700XP Half Module Electric Fry Top, Chromium Steel

Front

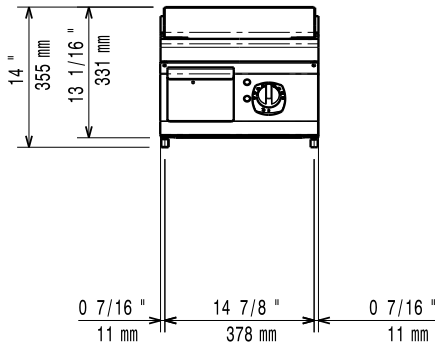

Top

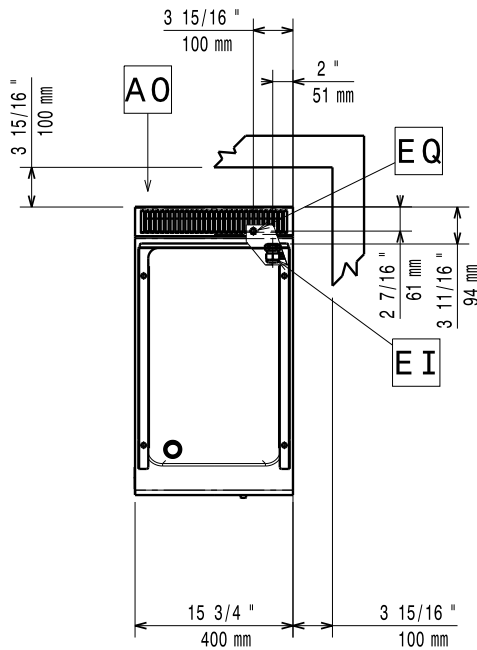

EI = Electrical connection
EQ = Equipotential screw

Side

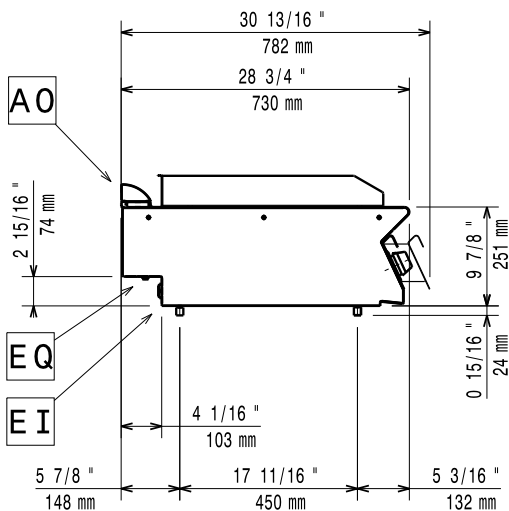

Electric

| | | |
|-------------------|---------------------|---------------------|
| Supply voltage: | 371193 (E7FTEDCSI0) | 400 V/3 ph/50/60 Hz |
| Electrical power: | | 4.2 kW |
| Total Watts: | | 4.2 kW |

Key Information:

| | |
|--------------------------|---------------------|
| Cooking surface width: | 330 mm |
| Cooking surface depth: | 540 mm |
| Working Temperature MIN: | 110 °C |
| Working Temperature MAX: | 280 °C |
| Net weight: | 40 kg |
| Shipping weight: | 47 kg |
| Shipping height: | 540 mm |
| Shipping width: | 460 mm |
| Shipping depth: | 820 mm |
| Shipping volume: | 0.22 m ³ |

If appliance is set up or next to or against temperature sensitive furniture or similar, a safety gap of approximately 150 mm should be maintained or some form of heat insulation fitted.



Modular Cooking Range Line
700XP Half Module Electric Fry Top, Chromium Steel

The company reserves the right to make modifications to the products without prior notice. All information correct at time of printing.