



Electrolux

Modular Cooking Range Line 700XP Full Module Electric Fry Top, Mild Steel

ITEM # _____

MODEL # _____

NAME # _____

SIS # _____

AIA # _____



Modular Cooking Range Line

700XP Full Module Electric Fry Top, Mild Steel

371186 (E7FTEHSSI0)	Full module electric fry top with smooth mild steel plate, thermostatic control
371199 (E7FTEHSSIN)	Full module electric fry top with smooth mild steel plate, thermostatic control
371187 (E7FTEHSPI0)	Full module electric fry top with 2/3 smooth and 1/3 ribbed mild steel plate, thermostatic control
371200 (E7FTEHSPIN)	Full module electric fry top with 2/3 smooth and 1/3 ribbed mild steel plate, thermostatic control

Short Form Specification

Item No. _____

To be installed on open base installations or bridging supports. Smooth cooking surface in mild steel. Temperature range from 110°C to 280°C. Removable drawer below the cooking surface for the collection of grease and fat. Exterior panels in stainless steel with Scotch Brite finish. One piece pressed work top in 1.5 mm thick stainless steel. Right-angled side edges to allow flush-fitting junction between units.

Main Features

- Unit to be mounted on open base cupboards, bridging supports or cantilever systems.
- Large drain hole on cooking surface permits the draining of fat into large 1,5 liter collector placed under the cooking surface.
- Large grease collection container available as optional accessory to be installed under top units over open base cupboard.
- Safety thermostat and thermostatic control.
- Stainless steel high splash guard on the rear and sides of cooking surface. Splash guard can be easily removed for cleaning.
- Temperature range of griddle from 110 °C to 300 °C.
- IPX 4 water protection.
- Infrared heating elements mounted below the cooking surface.

Construction

- Cooking surface in mild steel for optimum grilling results.
- Cooking surface to be completely smooth or 2/3 smooth and 1/3 ribbed.
- Exterior panel in Stainless Steel with Scotch Brite finish.
- One piece pressed 1.5 mm work top in Stainless steel.
- Model has right-angled side edges to allow flush fitting joints between units, eliminating gaps and possible dirt traps.

Optional Accessories

- Scraper for smooth plate fry tops PNC 164255
- Kit 4 wheels - 2 swivelling with brake - it is mandatory to install base support and wheels (only for 371186, 371187) PNC 206135
- Support for bridge type installation, 800mm PNC 206137
- Support for bridge type installation, 1000mm PNC 206138
- Support for bridge type installation, 1200mm PNC 206139
- Support for bridge type installation, 1400mm PNC 206140
- Support for bridge type installation, 1600mm PNC 206141
- Water column with swivel arm (water column extension not included) PNC 206289
- Water column extension for 700 line PNC 206291

APPROVAL: _____



Electrolux

Modular Cooking Range Line
700XP Full Module Electric Fry Top, Mild Steel

- Chimney upstand, 800mm PNC 206304
- Right and left side handrails PNC 206307
- Grease/oil kit container for 700 line frytops (half and module) and 900 line frytops (module) PNC 206346
- Rear paneling - 800mm (700/900) (only for 371186) PNC 206374
- Rear paneling - 1000mm (700/900) (only for 371186) PNC 206375
- Chimney grid net, 400mm (700XP/900) PNC 206400
- Scraper for ribbed plate fry tops - kit includes knife blades for both smooth and ribbed surface (only for 371187, 371200) PNC 206420
- Frontal handrail, 800mm PNC 216047
- Frontal handrail, 1200mm PNC 216049
- Frontal handrail, 1600mm PNC 216050
- Large handrail - portioning shelf, 400mm PNC 216185
- Large handrail - portioning shelf, 800mm PNC 216186
- 2 side covering panels for top appliances PNC 216277



Electrolux

**Modular Cooking Range Line
700XP Full Module Electric Fry Top,
Mild Steel**

Front

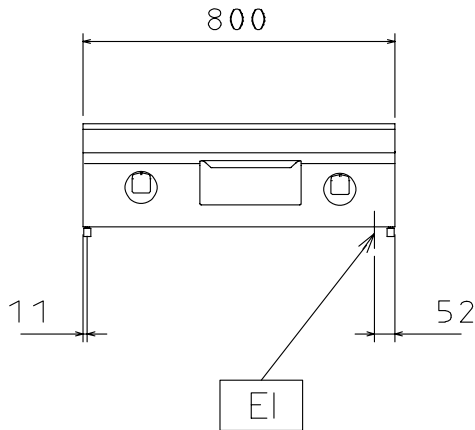

Top

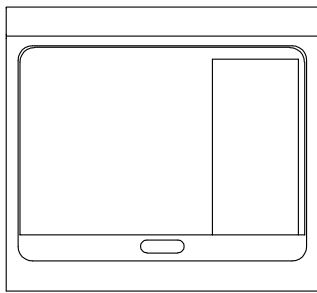

Side

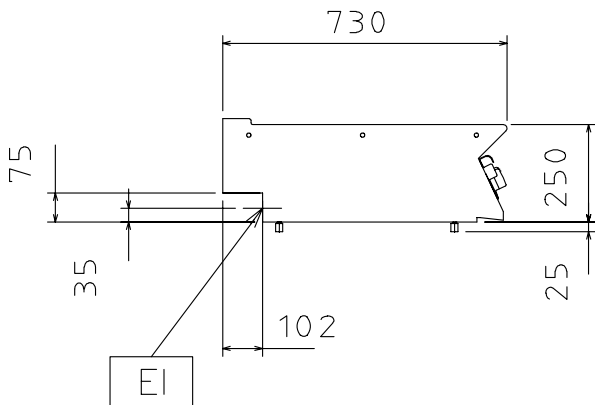

EI = Electrical connection
EQ = Equipotential screw

Electric

Supply voltage:

371186 (E7FTEHSSIO)	400 V/3 ph/50/60 Hz
371199 (E7FTEHSSIN)	230 V/3 ph/50/60 Hz
371187 (E7FTEHSPIO)	400 V/3 ph/50/60 Hz
371200 (E7FTEHSPIN)	230 V/3 ph/50/60 Hz

Electrical power:

371186 (E7FTEHSSIO)	8.4 kW
371199 (E7FTEHSSIN)	7.8 kW
371187 (E7FTEHSPIO)	8.4 kW
371200 (E7FTEHSPIN)	7.8 kW

Total Watts:

371186 (E7FTEHSSIO)	8.4 kW
371199 (E7FTEHSSIN)	7.8 kW
371187 (E7FTEHSPIO)	8.4 kW
371200 (E7FTEHSPIN)	7.8 kW

Key Information:

Cooking surface width:	730 mm
Cooking surface depth:	540 mm
Working Temperature MIN:	110 °C
Working Temperature MAX:	300 °C
Net weight:	70 kg
Shipping weight:	
371186 (E7FTEHSSIO)	75 kg
371199 (E7FTEHSSIN)	84 kg
371187 (E7FTEHSPIO)	84 kg
371200 (E7FTEHSPIN)	84 kg
Shipping height:	540 mm
Shipping width:	820 mm
Shipping depth:	860 mm
Shipping volume:	0.38 m ³

If appliance is set up or next to or against temperature sensitive furniture or similar, a safety gap of approximately 150 mm should be maintained or some form of heat insulation fitted.

Modular Cooking Range Line
700XP Full Module Electric Fry Top, Mild Steel

The company reserves the right to make modifications to the products without prior notice. All information correct at time of printing.

