

# Self Serve Hot Food Display

***The Woodson self serve hot food display is perfect for buffet situations, back of house applications, or anywhere that serviceability is a key factor.***



Optional sneeze guard



Quartz infra-red overhead heat lamps



Precise thermostat control

## FEATURES & BENEFITS

- Includes a tapered, symmetrical, toughened glass gantry to allow access from both sides
- Stainless steel construction with dual skin air-insulated bain marie tank for improved safety
- Multiple element design means unit will continue to operate in the event of single element failure
- Thermostat controls with clear temperature readout
- 15mm drain with downward emptying tap
- Overhead heat lamps wired to maximise light, heat and reliability - with lamp guard
- Full size gastronorm cavity to take choice of 65mm and 100mm pan combinations (pans not included)
- Easy to service via rear access panel
- Identical footprint to other Woodson food display models
- Can be run both wet and dry
- 3 bay supplied with 10 amp plug & lead
- 4, 5 & 6 bay supplied with 15 amp plug & lead



**W.HFSSxx**

MODEL	DESCRIPTION	DIMENSIONS (mm) (w x d x h)	POWER
W.HFSS23	3 module unit with rear sliding glass doors	1030 x 600 x 690	2.4kW - 10 Amp
W.HFSS24	4 module unit with rear sliding glass doors	1355 x 600 x 690	3.0kW - 15 Amp
W.HFSS25	5 module unit with rear sliding glass doors	1680 x 600 x 690	3.3kW - 15 Amp
W.HFSS26	6 module unit with rear sliding glass doors	2005 x 600 x 690	3.6kW - 15 Amp

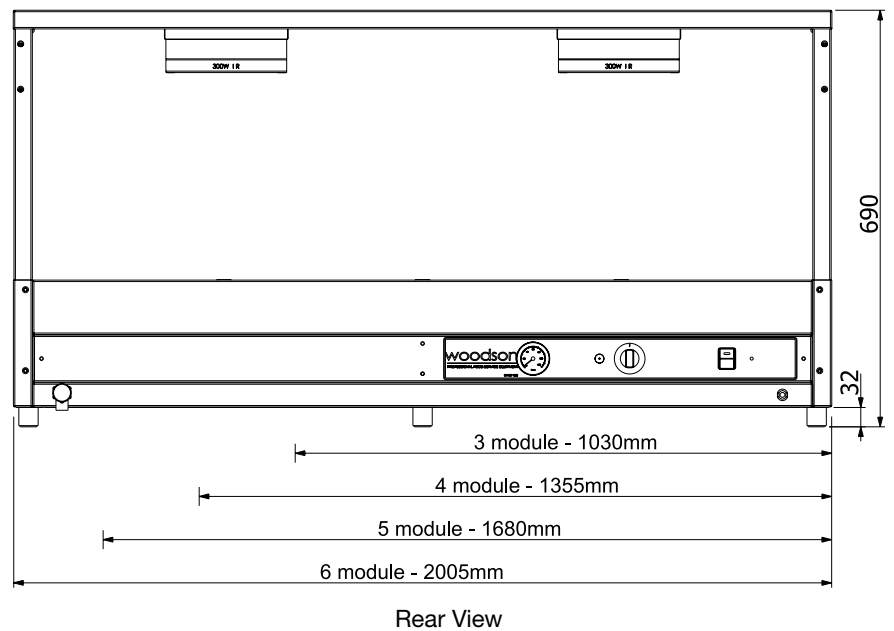
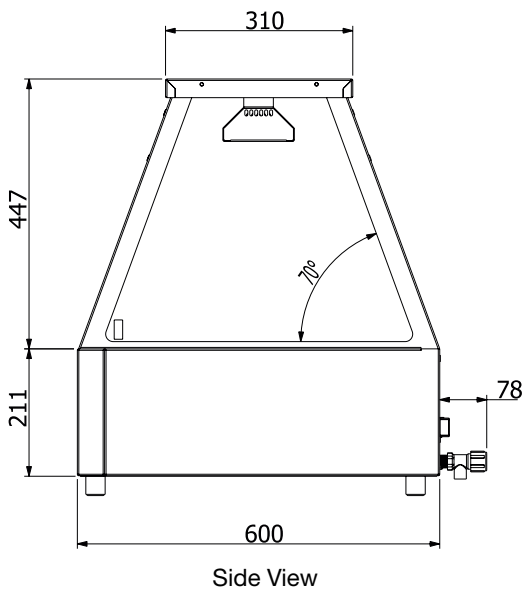

Dealer:

We reserve the right to alter specifications of products without notice. All dimensions are in mm.