

BC1SS-80

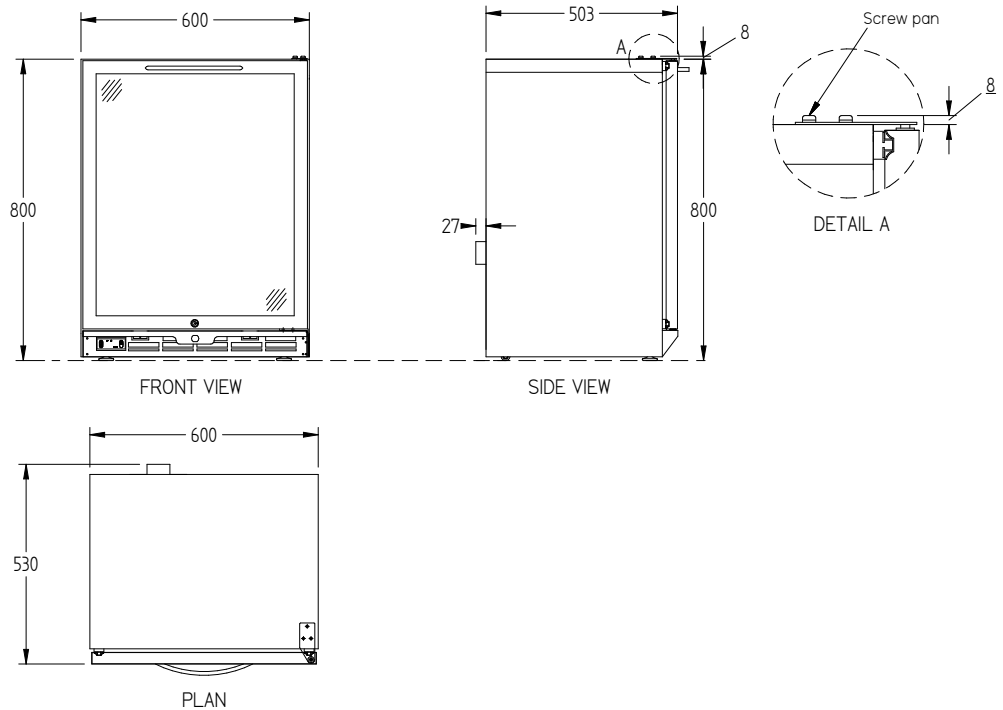

CATEGORY	GENERAL COUNTERS & BACK BARS
RANGE	Bottle Cooler
UNIT	REFRIGERATOR
TYPE	SELF CONTAINED
DOORS	1



SPECIFICATIONS

CAPACITY LITRES	190	
TEMPERATURE	1°C / 4°C	
DIMENSIONS - W X D X H MM	600 W x 530 D x 800 H	
WEIGHT UNPACKED (KG)	60	
DOOR TYPE	Standard: GD (Glass Door)	
FINISH (INTERIOR AND EXTERIOR EXCLUDING REAR AND UNDER)	SS (Stainless Steel)	
SHELVES/DOOR	2	
ELECTRICAL		
POWER SUPPLY	10 amp	
FRIDGE MODELS	RUNNING AMPS	1.8
GAS TYPE		
REFRIGERANT	FRIDGE MODELS	R134a

*** For **OPTIONS** refer to the current Williams Price Guide