

FRONT VIEW

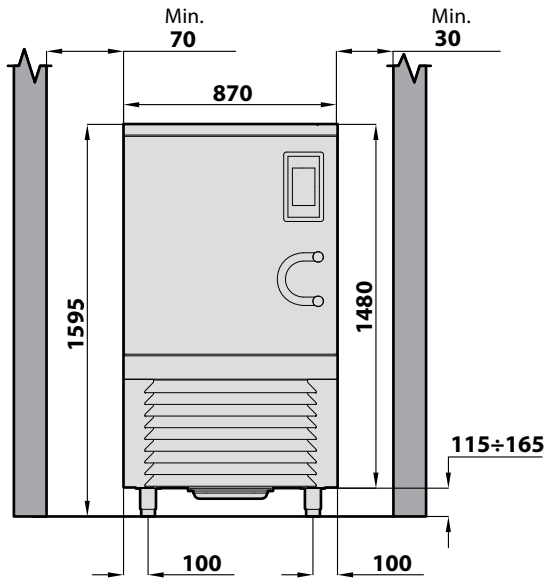

SIDE VIEW

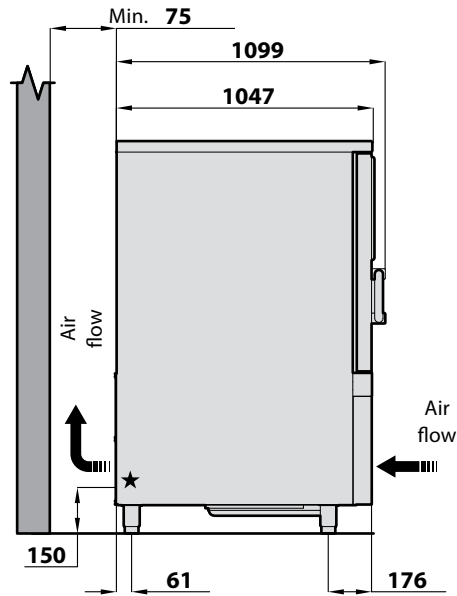

TOP VIEW

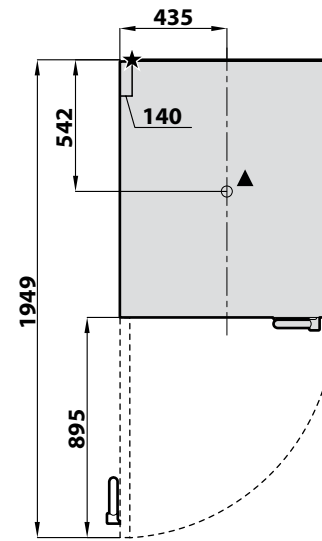

- ★ Main power cable
- ▲ Drain pipe ø 31

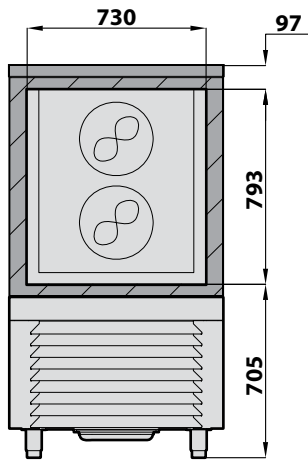

INTERIOR VIEW

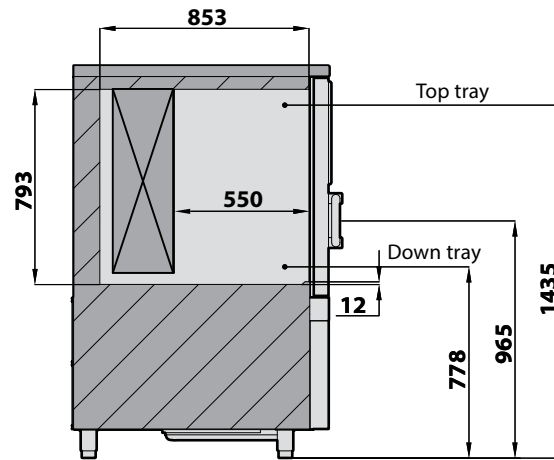

TRAYS CAPACITY		
Number of trays GN1/1 (H= 40 mm)	-	22
Number of trays GN2/1 (H= 40 mm)	-	12
Yield for blast chilling cycle: (90/+3°C)	kg	70,0
Yield for shock freezing cycle: (90/-18°C)	kg	70,0
*: within 90 min. **: within 240 min.		

HEIGHT			
		a	b
Standard feet	mm	1595	115 ÷ 165
Lowered feet option	mm	1560	60 ÷ 80
Wheel option	mm	1535	155

measurement in millimeters

IRINOX

Mod.: **MF 70.2 PLUS**

Cod.: **PMF0702PAAxxxx**

Ed.: **01/08/2018** Rev.: **00**

MULTI-FUNCTION BLAST CHILLER WITH INTEGRATED AIR CONDENSING UNIT

Electric supply:		400V 3N+PE 50Hz	400V 3N+PE 60Hz	230V 3+PE 50Hz	230V 3+PE 60Hz	200V 3+PE 50/60Hz
Total rating:	kW	5,20	5,30	5,20	6,50	5,40 / 6,60
Full load amps:	A	10,60	11,40	25,90	25,90	26,30 / 26,50
Main power cable	mm ²	5G1.5	5G1.5	4G4	4G4	4G4
Compressor rating	HP	4,0	4,0	4,0	4,0	4,0
Refrigeration Yield (-10/40°C)	W	8851	10305	8851	10305	8851 / 10305
Condenser rating (-10/40°C)	W	13053	15548	13053	15548	13053 / 15548
Refrigerant type:	-	R404A / R452A				
Nominal refrigerant charge:	kg gas	5,00				
Minimum Air Flow	m ³ /h	4000	4400	4000	4400	4000 / 4400
Maximum ambient air temperature:	°C	32				
Cabinet dimension: (W × D × H)	mm	890 × 1092 × 1595				
Cabinet weight:	kg	-				
Compressor Noise (5 m)	dB(A)	54,9	54,9	54,9	54,9	54,9 / 54,9

In implementation of the European Regulation 1095/2015 Irinox states that consumption is:

Model(S)	MF 70.2 PLUS (400V-3N+PE 50Hz)	
Type of product	Blast chiller / Blast freezer	
Refrigerant fluid(S)	-	R404A
Refrigerant charge	kg gas	5,00
Blast chilling program	Delicate +3 °C	
Blast freezing program	Strong -18 °C	
Energy consumption Blast chilling cycle	kWh/kg	0,0830
Energy consumption Blast freezing cycle	kWh/kg	0,1980
Chilled full load capacity	kg	70
Frozen full load capacity	kg	70
Blast chilling cycle from/to +65 °C / +10°C	min	90
Blast freezing cycle from/to +65 °C / -18°C	min	240
Contact details:	IRINOX Spa, Via Madonna di Loreto 6/B 31020 Corbanese di Tarzo (TV) Italy	

IRINOX

Mod.: **MF 70.2 PLUS**

Cod.: **PMF0702PAAxxxx**

Ed.: **01/08/2018** Rev.: **00**