



TRUE EUROPE

Field's End Road, Goldthorpe, Nr. Rotherham, South Yorkshire S63 9EU,
 United Kingdom • www.truemfg.com • Tel 01709 888 080 • Fax 01709 880 838
 • Free Phone 0 800 783 2049 • Free Phone to U.S. 0 800 894 928

Project Name: _____

Location: _____

Item #: _____ Qty: _____

Model #: _____

A/A #

S/S #

Model:
TUC-24G

Undercounter:
 Glass Door Refrigerator



TUC-24G

- ▶ True's undercounter units are designed with enduring quality that protects your long term investment.
- ▶ Designed using the highest quality materials and components to provide the user with colder product temperatures, lower utility costs, exceptional food safety and the best value in today's food service marketplace.
- ▶ Oversized, environmentally friendly (134A) forced-air refrigeration system holds 33°F to 38°F (.56°C to 3.33°C).
- ▶ 300 series stainless steel front and countertop. Matching aluminum sides and finished back.
- ▶ Attractive, white aluminum liner. 300 series stainless steel floor with coved corners.
- ▶ Energy efficient, "Low-E", double pane thermal insulated glass door(s).
- ▶ Front breathing.
- ▶ Heavy duty PVC coated wire shelves.
- ▶ Foamed-in-place using Ecomate. A new, innovative, high density, polyurethane insulation that has zero ozone depletion potential (ODP) and zero global warming potential (GWP).

ROUGH-IN DATA

Specifications subject to change without notice.
 Chart dimensions rounded up to the next whole millimeter (inches rounded up to the next 1/8").

Model	Doors	Capacity (liters)	Shelves	Cabinet Dimensions (mm)			HP	Voltage	Amps	NEMA Config.	Cord Length (total m)	Crated Weight (kg)
				L	D	H						
TUC-24G	1	147	2	610	632	832	1/6	230-240/50/1	1.3	▲	2.13	71

▲ Plug type varies by country.



5/10

Printed in U.S.A.

APPROVALS:

AVAILABLE AT:

Model:
TUC-24G

Undercounter:
Glass Door Refrigerator



STANDARD FEATURES

DESIGN

- True's commitment to using the highest quality materials and oversized refrigeration systems provides the user with colder product temperatures, lower utility costs, exceptional food safety and the best value in today's food service marketplace.

REFRIGERATION SYSTEM

- Factory engineered, self-contained, capillary tube system using environmentally friendly (CFC free) 134A refrigerant.
- Oversized, factory balanced refrigeration system with guided airflow to provide uniform product temperatures.
- Extra large evaporator coil balanced with higher horsepower compressor and large condenser; maintains cabinet temperatures of 33°F to 38°F (.5°C to 3.3°C) for the best in food preservation.
- Sealed, cast iron, self-lubricating evaporator fan motor(s) and larger fan blades give True undercounter units a more efficient, low velocity, high volume airflow design. This unique design ensures faster temperature recovery and shorter run times in the busiest of food service environments.
- Condensing unit access in back of cabinet, slides out for easy maintenance.

CABINET CONSTRUCTION

- Exterior - stainless steel front and countertop. Matching aluminum sides and finished back.
- Interior - attractive, white aluminum liner.
- 300 series stainless steel floor with coved corners.
- Insulation - entire cabinet structure is foamed-in-place using Ecomate. A new, innovative, high density, polyurethane insulation that has zero ozone depletion potential (ODP) and zero global warming potential (GWP).
- Two (2) front leg levelers and Two (2) rear recessed castors. 32 ¾" (832 mm) work surface height.

DOOR

- "Low-E", double pane thermal insulated glass assembly with extruded aluminum frame(s).
- Door fitted with 12" (305 mm) long extruded aluminum handle.
- Positive seal self-closing door. Door swings within cabinet dimensions.
- Magnetic door gasket of one piece construction, removable without tools for ease of cleaning.

SHELVING

- Shelf support pilasters made of same material as cabinet interior; shelves are adjustable on ½" (13 mm) increments.

MODEL FEATURES

- Evaporator is epoxy coated to eliminate the potential of corrosion.
- Self-contained condensate pan. No need for external drain.

ELECTRICAL

- Unit completely pre-wired at factory and ready for final connection to a 230-240/50/1 phase dedicated outlet.
- Plug type varies by country.

OPTIONAL FEATURES/ACCESSORIES

Upcharge and lead times may apply.

- 230 - 240V / 50 Hz.
- Barrel lock (factory installed).
- 30" (762 mm) deep, ½" (13 mm) thick, white polyethylene cutting board. Requires "L" brackets.
- 30" (762 mm) deep, ½" (13 mm) thick, composite cutting board. Requires "L" brackets.
- Exterior rectangular digital temperature display (factory installed).

PLAN VIEW

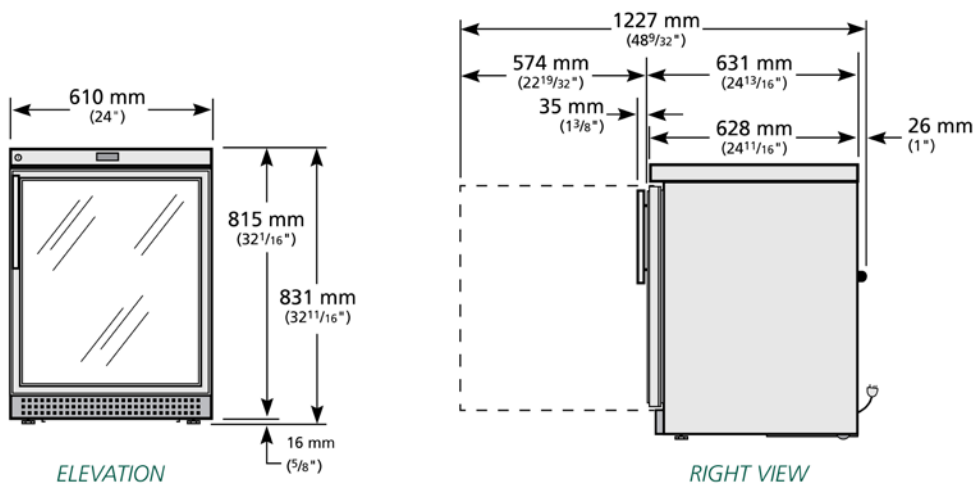

METRIC DIMENSIONS ROUNDED UP TO THE NEAREST WHOLE MILLIMETER
SPECIFICATIONS SUBJECT TO CHANGE WITHOUT NOTICE

	Model	Elevation	Right	Plan	3D	Back
	TUC-24G					

TRUE EUROPE